



ARIB STD-T50

ENGLISH TRANSLATION

OPTICAL WIRELESS LAN SYSTEM

ARIB STANDARD

VERSION 3.0

ARIB STD-T50

Version 1.0	February	18	1997
Version 2.0	May	30	2002
Version 3.0	December	12	2006

Association of Radio Industries and Businesses (ARIB)

General Notes to the English translation of ARIB Standards and Technical Reports

1. The copyright of this document is ascribed to the Association of Radio Industries and Business (ARIB).
2. All right reserved. No part of this document may be reproduced, stored in a retrieval system, or transmitted, in any form or by any means, without the prior written permission of ARIB.
3. The ARIB Standards and ARIB Technical Reports are usually written in Japanese and approved by the ARIB Standard Assembly. This document is a translation into English of the approved document for the purpose of convenience of users. If there are any discrepancies in the content, expressions, etc., between the Japanese original and this translated document, the Japanese original shall prevail.
4. The establishment, revision and abolishment of ARIB Standards and Technical Reports are approved at the ARIB Standard Assembly, which meets several times a year. Approved ARIB Standards and Technical Reports, in their original language, are made publicly available in hard copy, CDs or through web posting, generally in about one month after the date of approval. The original document of this translation may have been further revised and therefore users are encouraged to check the latest version at an appropriate page under the following URL: <http://www.arib.or.jp/english/index.html>

Introduction

The Association of Radio Industries and Businesses (ARIB) establishes basic requirements such as standard specifications for radio equipment relating to each system that uses radio waves and makes them 'standard' with the participation of radio equipment manufacturers, operators, broadcasters and users.

This standard is a private one that is based on two standards: a national technical standard for the purpose of effective use of radio frequencies and avoidance of interference among users, and a private optional standard for the purpose of convenience of radio equipment manufacturers and users.

This standard is established principally for "Optical wireless LAN system". In order to ensure fairness, impartiality, and openness among all parties involved, during the drafting stages, we invited radio equipment manufactures, telecommunications operators, broadcasting companies, test organizations, and users, both domestic and foreign, to participate openly in the activities of the Standard Assembly so as to develop standards with the total agreement of all parties involved.

We hope that this standard will aid all parties involved, including radio equipment manufacturers, test organizations, users, and other interested parties.

Contents

Chapter 1 Overview	1
1.1 Introduction	1
1.2 Prerequisite	1
1.3 Definitions	2
 Chapter 2 MAC and PLS Sublayers, AUI, and Repeater Units (10Mbps)	 3
2.1 Media Access Control (MAC) Service Specification	3
2.2 MAC (Media Access Control) Frame Structure	3
2.3 Media Access Control	3
2.4 Layer Management	3
2.5 PLS (Physical Signaling) Service Specifications	3
2.6 PLS Sublayer and AUI (Attachment Unit Interface) Specifications	3
2.7 Repeater Unit for 10Mbps Baseband Network	3
 Chapter 3 Optical Wireless Media Access Unit (MAU) and Baseband Medium (10Mbps Baseband Optical Wireless Type)	 4
3.1 Scope	4
3.1.1 Overview	4
3.1.2 Definitions	6
3.1.3 Application perspective	7
3.1.4 Relationship between PLS and AUI	7
3.2 MAU Functional Specifications	7
3.2.1 Functions of MAU	8
3.2.2 PMA interface message	9
3.2.3 MAU state diagram	10
3.3 MAU-MDI Characteristics	10
3.3.1 Transmission function	10
3.3.2 Receive function	10
 Chapter 4 Examples of Systems to be Implemented (10Mbps)	 12
 Chapter 5 MAC Layer (100Mbps)	 18

5.1	MAC Services	18
5.2	MAC Frame Structure	18
5.3	Media Access	18
5.4	Layer Management	18
5.5	MII specification and RS layer	18
5.6	Repeater unit	18
5.6.1	Overview	18
5.6.2	Propagation delay	20
Chapter 6 Physical Layer (PHY) and Optical Wireless Baseband Medium (100Mbps)		21
6.1	Scope	21
6.1.1	Overview	21
6.1.2	Definitions	22
6.1.3	Application perspective	23
6.1.4	PHY topologies	23
6.2	Functional specifications of optical wireless type PHY	24
6.2.1	PHY functions	25
6.2.2	Management interface	26
6.2.3	Frame structure	26
6.3	Optical signal provisions	26
6.3.1	Transmission function	26
6.3.2	Receive function	27
Chapter 7 Examples of Systems to be Implemented		28
7.1	One-to-one System	28
7.2	One-to-n System	28
Chapter 8 Beam Profile of the Optical Wireless Medium		31
Chapter 9 MAC Layer (1000 Mbps)		32
9.1	MAC Services	32
9.2	MAC Frame Structure	32
9.3	Media Access	32
9.4	Layer Management	32
9.5	GMII specification and RS layer	32

9.6 Repeater Unit	32
9.6.1 Overview	32
9.6.2 Propagation delay	33
Chapter 10 Physical Layer (PHY) and Optical Wireless Baseband Medium (1000 Mbps)	34
10.1 Scope	34
10.1.1 Overview	34
10.1.2 Definitions	35
10.1.3 Application perspective	36
10.1.4 PHY topologies	36
10.2 Functional Specifications of Optical Wireless Type PHY	37
10.2.1 PHY functions	38
10.2.2 Management interface	39
10.2.3 Frame structure	39
10.2.4 Optical Signal Provisions	39
10.3.1 Transmission function	39
10.3.2 Receive function	40
Chapter 11 Installation of Devices	41
References	42

Chapter 1 Overview

1.1 Introduction

This standard provides for 10Mbps optical wireless LAN, 100Mbps optical wireless LAN, and 1000Mbps optical wireless LAN systems that adopt optical wireless media as physical layers to secure compatibility with the ISO/IEC 8802-3:2000 "CSMA/CD Local Area Network (LAN) Specification".

Hence, it allows connection of Data Terminal Equipment (DTE) that is to be connected to an existing Ethernet.

1.2 Prerequisite

This standard provides for the 10Mbps optical wireless LAN, 100Mbps optical wireless LAN, and 1000Mbps optical wireless LAN systems, which are compatible with ISO/IEC 8802-3:2000.

This standard also follows the format of ISO/IEC 8802-3:2000.

ISO/IEC 8802-3:2000 is roughly classified into the two categories, a common section which does not depend on transmission medium and the other section, which is medium-dependent. For the section which does not depend on transmission media, this standard cites the provisions of the ISO/IEC 8802-3:2000 as they are, while, for the medium-dependent section, it cites the provisions of the type 10BASE-T, the provisions of the type 100BASE-T, the provisions of the type 1000BASE-T, X as required, and additionally cites those of the 10 Mbps, 100Mbps, and 1000Mbps baseband optical wireless types, revised as necessary. In making additions and modifications, attention has been paid to meet the basic requirements for mutual connectability of products while at the same time seeking to ensure the freedom for implementation in products and retaining the latitude for future improvements in the element technology.

More concretely, the requirements for the MAC and PLS sublayers, AUI, and repeater units with regard to the 10Mbps optical wireless LAN have been cited from Chapters 2 through 7, and 9 of the ISO/IEC 8802-3:2000. Chapter 3 of this standard cites the provisions of Chapter 14 of the ISO/IEC 8802-3:2000 as required, and the provisions related exclusively to the optical wireless units are added to them. The requirements for the MAC sublayer and media access protocol for 100Mbps and 1000Mbps optical wireless LAN have been cited from Chapters 2 through 4 of the ISO/IEC 8802-3:2000. Chapter 6 of this standard cites the provisions of Chapters 21, 22, and 24 through 31 of the ISO/IEC 8802-3:2000 as required,

and the provisions related exclusively to the optical wireless units are added to them. Chapter 10 of this standard cites the provisions of Chapters 34 through 37 and Chapters 40 through 43 of the ISO/IEC 8802-3:2000 as required, and the provisions related exclusively to the optical wireless units are added to them.

1.3 Definitions

The basic concepts, architectural perspectives, layer interfaces, notations, cited specifications, and definitions of terms of this standard conform to those provided for in Chapter 1 of the ISO/IEC 8802-3:2000.

Chapter 2 MAC and PLS Sublayers, AUI, and Repeater Units (10Mbps)

2.1 Media Access Control (MAC) Service Specification

Section 2.1 shall conform to the provisions in Chapter 2 of the ISO/IEC 8802-3:2000.

2.2 MAC (Media Access Control) Frame Structure

Section 2.2 shall conform to the provisions in Chapter 3 of the ISO/IEC 8802-3:2000.

2.3 Media Access Control

Section 2.3 shall conform to the provisions in Chapter 4 of the ISO/IEC 8802-3:2000.

2.4 Layer Management

Section 2.4 shall conform to the provisions in Chapter 5 of the ISO/IEC 8802-3:2000.

2.5 PLS (Physical Signaling) Service Specifications

Section 2.5 shall conform to the provisions in Chapter 6 of the ISO/IEC 8802-3:2000.

2.6 PLS Sublayer and AUI (Attachment Unit Interface) Specifications

Section 2.6 shall conform to the provisions in Chapter 7 of the ISO/IEC 8802-3:2000.

2.7 Repeater Unit for 10Mbps Baseband Network

Section 2.7 shall conform to the provisions in Chapter 9 of the ISO/IEC 8802-3:2000.

Chapter 3 Optical Wireless Media Access Unit (MAU) and Baseband Medium (10Mbps Baseband Optical Wireless Type)

3.1 Scope

3.1.1 Overview

Chapter 3 defines the functional, electrical, and optical characteristics of the 10Mbps baseband optical wireless MAU and the specific baseband medium for use with the MAU. The relationship of the provisions of the 10Mbps baseband optical wireless type to the OSI reference model of the ISO and CSMA/CD LAN model of the ISO/IEC 8802-3:2000 is shown in Fig. 3-1. The purpose of the MAU is to provide a simple, inexpensive, and flexible means of attaching devices to the medium.

The provisions of Chapter 3 are based on those of Chapters 1 through 7 and 9 of the ISO/IEC 8802-3:2000. The MAU and baseband medium specification is aimed primarily at office applications and is expected to be applied to networks whose transmission areas cover from about one meter to several tens of meters.

Simplicity in installation and reconfiguration is allowed by use of the optical wireless type MAU and baseband medium. Moreover, since light beams are blocked at walls and are attenuated after passing through exterior windows, the characteristics of the optical system include the ability to substantially reduce the possibility of interference in communications and external wiretapping.

On the other hand, the safety regulations on photoradiation are under review by the Technical Committee TC-76 of the IEC. A standard has been established as IEC 60825-1 Edition 1.2. This standard will comply with this standard in methods of measurement and classification.

OSI Reference ModelThis standard

Fig. 3-1 The relationship of the provisions of the 10Mbps baseband optical wireless type to the OSI reference model of the ISO and the CSMA/CD LAN model of the ISO/IEC 8802-3:2000

3.1.1.1 Media Access Unit (MAU)

The MAU has the following general characteristics:

- (1) Enables coupling of the physical layer signaling (PLS) sublayer by way of the Attachment Unit Interface (AUI) to the optical wireless link defined in Chapter 3.
- (2) Supports message traffic at a data rate of 10Mbps.
- (3) Permits the Data Terminal Equipment (DTE) or repeater to confirm operation of the MAU and availability of the baseband medium.
- (4) Supports network configurations using the CSMA/CD access method defined in the ISO/IEC 8802-3:2000 with baseband signaling.
- (5) Supports a point-to-point or a star interconnection between MAUs.
- (6) MAU can be contained within DTE or repeater unit.

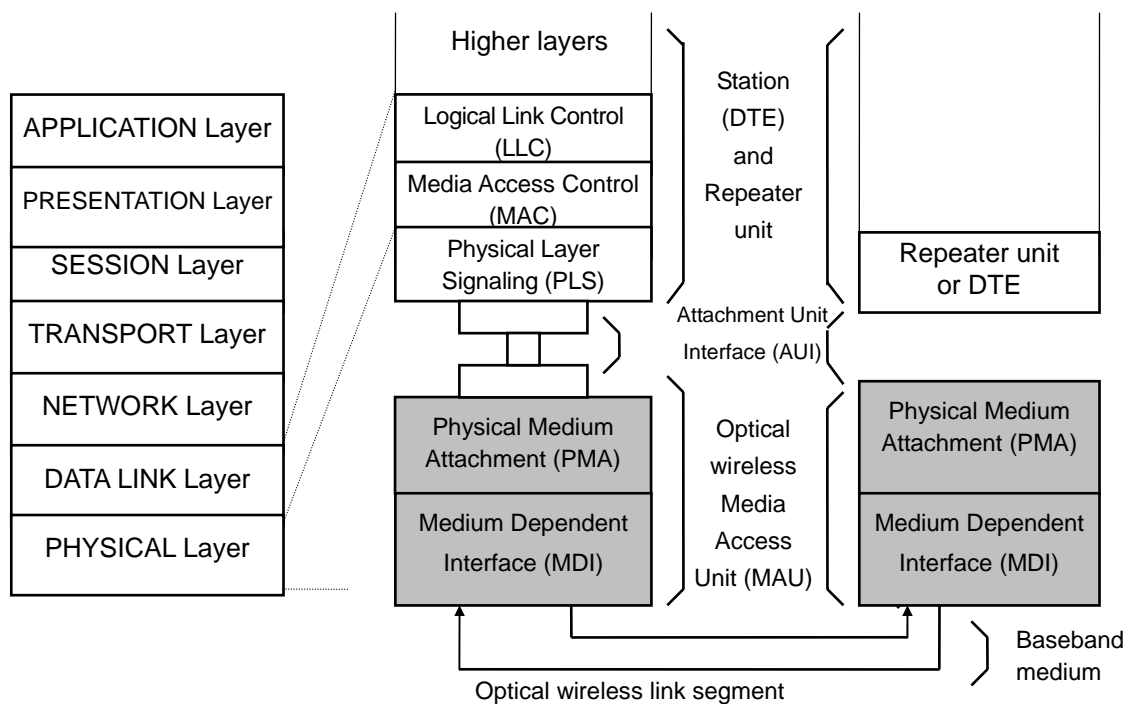
3.1.1.2 Repeater unit

The repeater unit is used to extend the physical system topology and provides for coupling multiple segments. Repeaters are an essential part of 10Mbps baseband optical wireless

networks with multiple DTEs. The repeater unit is defined in Chapter 9 of the ISO/IEC 8802-3:2000. The repeater unit is not a DTE and therefore has slightly different requirements for the attachment with MAUs, as defined in 9.4.1 of ISO/IEC 8802-3:2000. Repeater units with 10Mbps baseband optical wireless MAUs must provide the autopartition/reconnection algorithm on those ports, as specified in 9.6.6.2 of the ISO/IEC 8802-3:2000.

3.1.1.3 Optical wireless media

The physical medium used in the 10Mbps baseband optical wireless system is light, and its wavelength ranges from 680 nm to 1600 nm. The light-emitting elements used are LED or LD and photo-receiving elements are PD. However, this does not preclude new elements from being developed and adopted.

3.1.2 Definitions

This section defines the terminology specific to 10Mbps baseband optical wireless MAUs and their application to repeater units.

(1) Bit Time (BT)

The duration of one bit symbol ($1/BR$).

(2) Collision

An undesirable condition that results from concurrent transmission from multiple signal sources.

(3) Medium Dependent Interface (MDI)

Optical and electrical interface between the optical wireless link segment and the MAU.

(4) Physical Medium Attachment (PMA) sublayer

The portion of the MAU that contains the functional circuitry.

(5) Physical Layer Signaling (PLS) sublayer

The portion of the Physical Layer, contained within the DTE, that provides the logical and functional coupling between the MAU and the Data Link Layer.

(6) Simplex link segment

A wireless path between two optical wireless MAUs, including terminal connectors.

(7) Optical wireless link

Optical wireless link segment and two MAUs connected to it.

(8) Optical wireless link segment (duplex link segment)

Two simplex link segments for connecting two MAUs.

(9) Light Emitting Diode (LED)

A diode that irradiates light beams. It converts electricity into light.

(10) Photo Detector (PD)

A diode that detects light beams. It converts light into electricity.

3.1.3 Application perspective

This section states broad objectives and assumptions underlying the specifications defined through Chapter 3.

- (1) Provide the physical means for communication between LAN Data Link Layer Entities.
- (2) Provide a communication channel with a mean bit error rate, at the physical layer service interface, of 10^{-8} or lower.
- (3) Provide for ease of installation and maintenance.
- (4) Ensure that fairness of DTE access is not compromised.
- (5) Provide for low-cost networks.

3.1.4 Relationship between PLS and AUI

Chapters 3 and 2 (Section 2.6) are closely related to each other. Chapter 3 specifies the physical medium parameters and the PMA logical functions residing in the physical MAU. The MAU provides services to the PLS defined in Chapter 2 by means of the AUI. The 10 Mbps baseband optical wireless MAUs support a subset of the AUI services specified in Chapter 2 (Section 2.6). However, they do not support the optional isolate function, the optional CO circuit, or the optional CS1 signal on the CI circuit.

The design of an external MAU component requires the reference of both Chapter 3 and 2 (Section 2.6) for the PLS and AUI specifications.

The figures and numerous descriptions in the text throughout Chapter 3 refer to terminology associated with the AUI (that is, DO, DI, and CI). They are defined in conformity with the provisions in 7.5.2 of the ISO/IEC 8802-3:2000. Since an embodiment of the 10 Mbps baseband optical wireless MAU does not require the implementation of an AUI, it is not necessary for DO, DI, and CI to physically exist. However, they are logically present and MAU operation is defined in terms of them.

3.2 MAU Functional Specifications

The MAU provides the means by which signals on the three AUI signal circuits (which are used in transactions with the DTE and the repeater) and their associated interlayer messages are coupled to the optical wireless link segment. The MAU provides the following

functional capabilities to handle message flow between the DTE or repeater and the optical wireless link segment.

(1) Transmit function

The ability to transfer Manchester-encoded data from the DO circuit to the TD circuit. While not sending Manchester-encoded data on the TD circuit, the MAU sends the TP IDL idle signal by the TD circuit.

(2) Receive function

The ability to transfer Manchester-encoded data from the RD circuit to the DI circuit. While not sending Manchester-encoded data on the DI circuit, the MAU sends an IDL idle signal by the DI circuit.

(3) Loopback function

The ability to transfer Manchester-encoded data from DO to the DI circuit, when the MAU is sending Manchester-encoded data to the TD circuit.

(4) Collision Presence function

The ability to detect the simultaneous occurrence of Manchester-encoded data on the RD and DO circuits and to report such an occurrence as a collision.

(5) Signal quality error message (SQE) test function

The ability to indicate to the DTE that the Collision Presence function is operational and that the signal quality error message can be sent by the MAU.

(6) Jabber function

The ability to prevent abnormally long reception of Manchester-encoded data on the DO circuit from indefinitely disrupting transmission on the network. While such a condition is present, transfer of Manchester-encoded data by the Transmit and Loopback functions is disabled.

(7) Link Integrity Test function

The ability to protect the network from the consequences of failure of the simplex link segment attached to the RD circuit. While such a failure is present, transfer of Manchester-encoded data by the Transmit, Receive, and Loopback functions is disabled.

3.2.1 Functions of MAU

The MAU provides the Transmit, Receive, Loopback, Collision Presence, Jabber, and Link Integrity Test functions. The SQE Test function is performed by MAUs that are connected to DTEs and not by MAUs that are connected to repeaters. The SQE Test function activation and inhibition feature is provided in the MAU. The MAU is not required to determine

whether it is connected to a DTE or a repeater and to automatically activate or inhibit the SQE Test function.

3.2.1.1 Transmit function requirements

The requirements conform to the provisions of 14.2.1.1 of the ISO/IEC 8802-3:2000. However, both idle signal TP IDL and the link test pulse do not conform to those provided in 14.2.1.1 of the ISO/IEC 8802-3:2000, but are defined in 3.9.3.1.4 and 3.9.3.1.6 of this standard, respectively. This standard interprets the description on differential signals of the TD circuit in 14.2.1.1 of the ISO/IEC 8802-3:2000 as non-differential ones.

3.2.1.2 Receive function requirements

The requirements conform to the provisions of 14.2.1.2 of the ISO/IEC 8802-3:2000. However, this standard interprets the description on differential signals of the RD circuit in 14.2.1.2 of the ISO/IEC 8802-3:2000 as non-differential ones.

3.2.1.3 Loopback function requirements

The requirements conform to the provisions of 14.2.1.3 of the ISO/IEC 8802-3:2000. As far as the provisions on jitter are concerned, however, this standard interprets the description of differential signals in 14.3.1.3.1 of the ISO/IEC 8802-3:2000 as applying to non-differential signals.

3.2.1.4 Collision Presence requirements

The requirements conform to the provisions of 14.2.1.4 of the ISO/IEC 8802-3:2000.

3.2.1.5 Signal quality error message (SQE) test function requirements

The requirements conform to the provisions of 14.2.1.5 of the ISO/IEC 8802-3:2000.

3.2.1.6 Jabber function requirements

The requirements conform to the provisions of 14.2.1.6 of the ISO/IEC 8802-3:2000.

3.2.1.7 Link Integrity Test function requirements

The requirements conform to the provisions of 14.2.1.7 of the ISO/IEC 8802-3:2000. However, the provisions on timer values given in 14.2.1.7 of the ISO/IEC 8802-3:2000 should be replaced by the following values:

Timer	Value
Link loss	150 ms or less
Link test max	150 ms or less
Link test min	invalid

The provisions in the fifth paragraph depend substantially upon the specific implementation, and so they are excluded from consideration here.

3.2.2 PMA interface message

The requirements conform to the provisions of 14.2.2 of the ISO/IEC 8802-3:2000. However,

the term "Twisted Pair Link Segment" in 14.2.2.3 and 14.2.2.4 of the ISO/IEC 8802-3:2000 read "Optical Wireless Link Segment."

3.2.3 MAU state diagram

These requirements conform to those provided in 14.2.3 of the ISO/IEC 8802-3:2000.

3.3 MAU-MDI Characteristics

3.3.1 Transmission function

3.3.1.1 Light emission

Light is emitted when the logical level of TD is "1" and not emitted when it is "0."

3.3.1.2 Peak emission wavelength

The recommended peak emission wavelength on the transmitting side lies within the 680–1600 nm range. However, this provision does not preclude waveforms outside this range from being used.

3.3.1.3 Output power

For indoor applications, Class 1 as provided for in IEC 60825-1 Edition 1.2 is recommended, and for outdoor applications, Class 1 or 1M is recommended.

3.3.1.4 TP IDL

The signal TP IDL is produced in response to the IDL signal entered from the PLS. This always starts from the logic of "1" is retained for a period of 2.5 BT or more but 5 BT or less, and then is set to the logic of "0".

3.3.1.5 Link test pulse

Link test pulse is transmitted immediately after the TP IDL signal and repeats the logic of "0" and "1" for the period of 1.7 BT or more but 5 BT or less, until subsequent CD1 and CD0 are entered.

3.3.1.6 Output jitter

Allowable jitter value to be added in MAU is within ± 5 ns.

3.3.2 Receive function

3.3.2.1 Light sensing

When light is detected, the logic of "1" is generated to RD, and when no light is detected, the logic of "0" is generated.

3.3.2.2 Receiving sensitivity

When light reception is at the minimum irradiance level, the bit error rate (BER) should be 10^{-8} or better. The minimum irradiance is a level of $10 \mu\text{W}/\text{cm}^2$.

3.3.2.3 Idle input operation

Within 2.3 BT after the final logic of "0" is changed into the logic of "1" in the receive operation, an idle state must be detected.

3.3.3.4 Input jitter

Allowable jitter value to be added in MAU is within ± 3 ns.

Chapter 4 Examples of Systems to be Implemented (10Mbps)

(1) One-to-one long-distance system

This is a one-to-one system applicable to relatively long distances (20m).

It is targeted mainly at office through space applications.

The component comprising this system is a one-to-one long-distance repeater composed of 10BASE-T MAU, a repeater unit, and an optical wireless MAU.

By using a couple of one-to-one long-distance repeaters, separated twisted-pair link segments can be connected with an optical wireless system.

Since the optical unit is directional in this system, it is possible to use more than one system in a single space.

A typical topology of this system is illustrated in Fig.4-1.

(2) One-to-n medium-distance system

This is a one-to-n system applicable to medium distances (a few meters apart).

The component comprising this system is a one-to-n medium-distance repeater and a one-to-one medium-distance repeater. Both repeaters are composed of 10BASE-T MAU, a repeater unit, and an optical wireless MAU in a one-piece body. The former is usually installed on the ceiling or a wall, while the latter is usually installed on a desk.

By using a one-to-n medium-distance repeater installed on the ceiling or a similar position and a one-to-one medium-distance repeater installed on a desk or similar position, a twisted-pair link segment on the desk can be easily connected with other twisted-pair link segments.

Like a one-to-one long-distance repeater, the one-to-one medium-distance repeater has a directional optical unit, and more than one repeater can be installed in a single space.

On the other hand, the one-to-n version has wider directivity to allow connection with more than one one-to-one medium repeater.

A typical topology of this system is illustrated in Fig.4-2.

The optical wireless MAU for the one-to-n medium-distance repeater is logically connected to the two ports, A and B; the TD circuit is connected to the DO circuit of Port A while the RD circuit is connected to the DI circuit of Port B.

Hence, a signal inputted in this component through an optical wireless link segment from a one-to-one medium-distance repeater is transmitted to the optical wireless link segment as well as to the 10BASE-T-side through the repeater unit in the component and is received by the other one-to-one medium-distance repeater.

On the other hand, the optical wireless MAU in the one-to-one medium-distance repeater receives a signal from another component looped back from the one-to-n medium-distance repeater as stated above while the MAU is transmitting the signal to the optical wireless link segment. The relevant optical wireless MAU compares the data transmitted from the TD circuit and those received at the RD circuit, then it is not transmitting the data received at RD circuit to DI circuit while the data is matched, transmitting to DI circuit when it is unmatched.

Herewith the repeater can always monitor whether a collision exists or not, which means whether or not the data it transmits to the optical wireless link segment are not corrupted by a collision.

(3) One-to-one short-distance system

This is a one-to-one system for short distances (approximately one meter).

It is aimed mainly at portable terminal applications.

The components comprising this system includes a one-to-one short-distance repeater in which 10BASE-T MAU, a repeater unit, and an optical wireless MAU are integrated in a one-piece body, and a card-type MAU-incorporated DTE interface to convert signals between the DTE and the optical wireless link segment.

By using the card-type MAU-incorporated DTE interface and the one-to-one short-distance repeater, an optical wireless system can connect a twisted-pair link segment and a portable terminal unit within a short distance.

This component has wide directivity to facilitate connectivity between facing components.

A typical topology of this system is illustrated in Fig.4-3.

(4) Specifications of respective components

Table 4-1 shows the specifications of the one-to-one long-distance system, one-to-n medium-distance system, and one-to-one short-distance system, respectively.

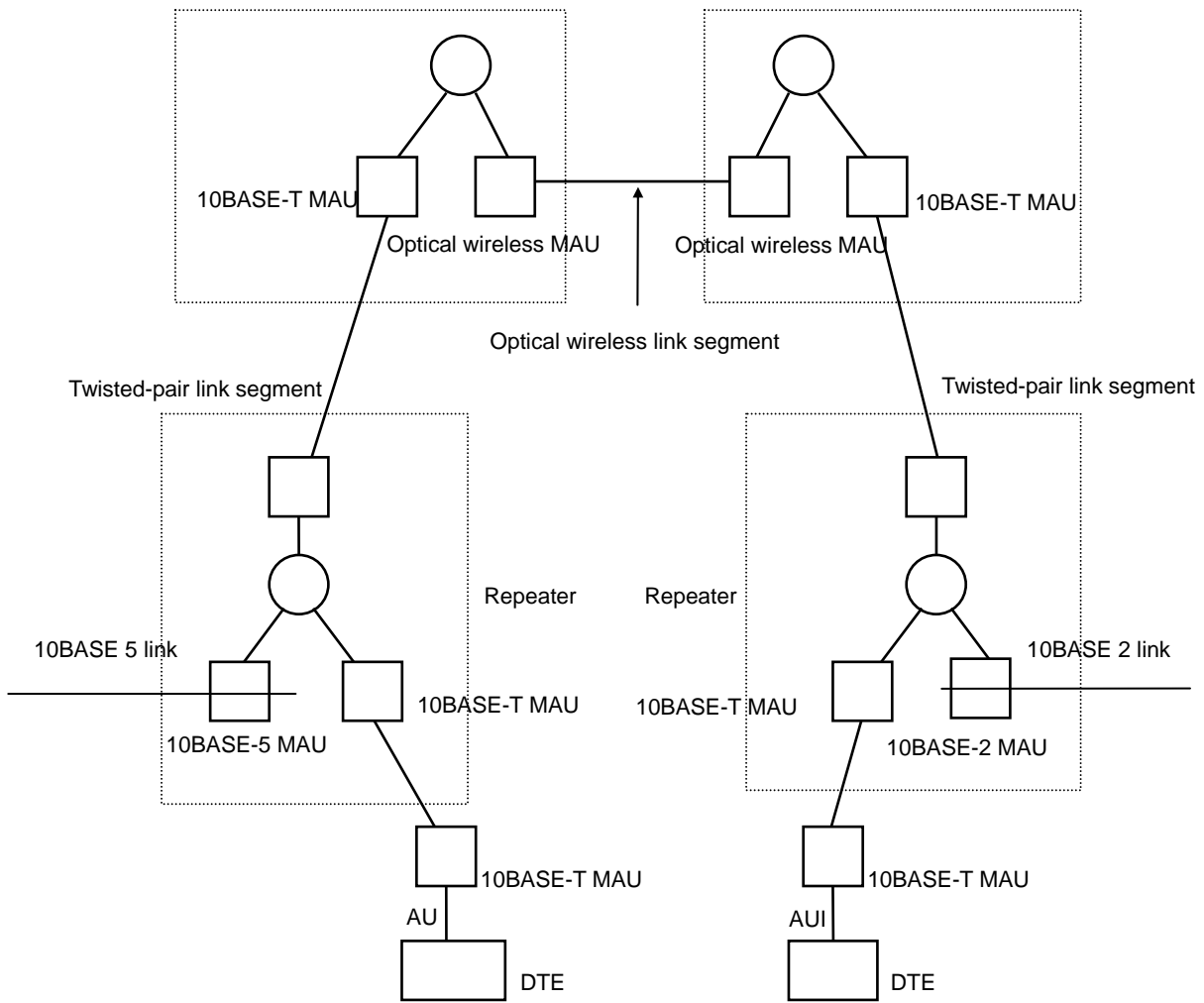

Fig. 4-1 Typical topology of a one-to-one long-distance system

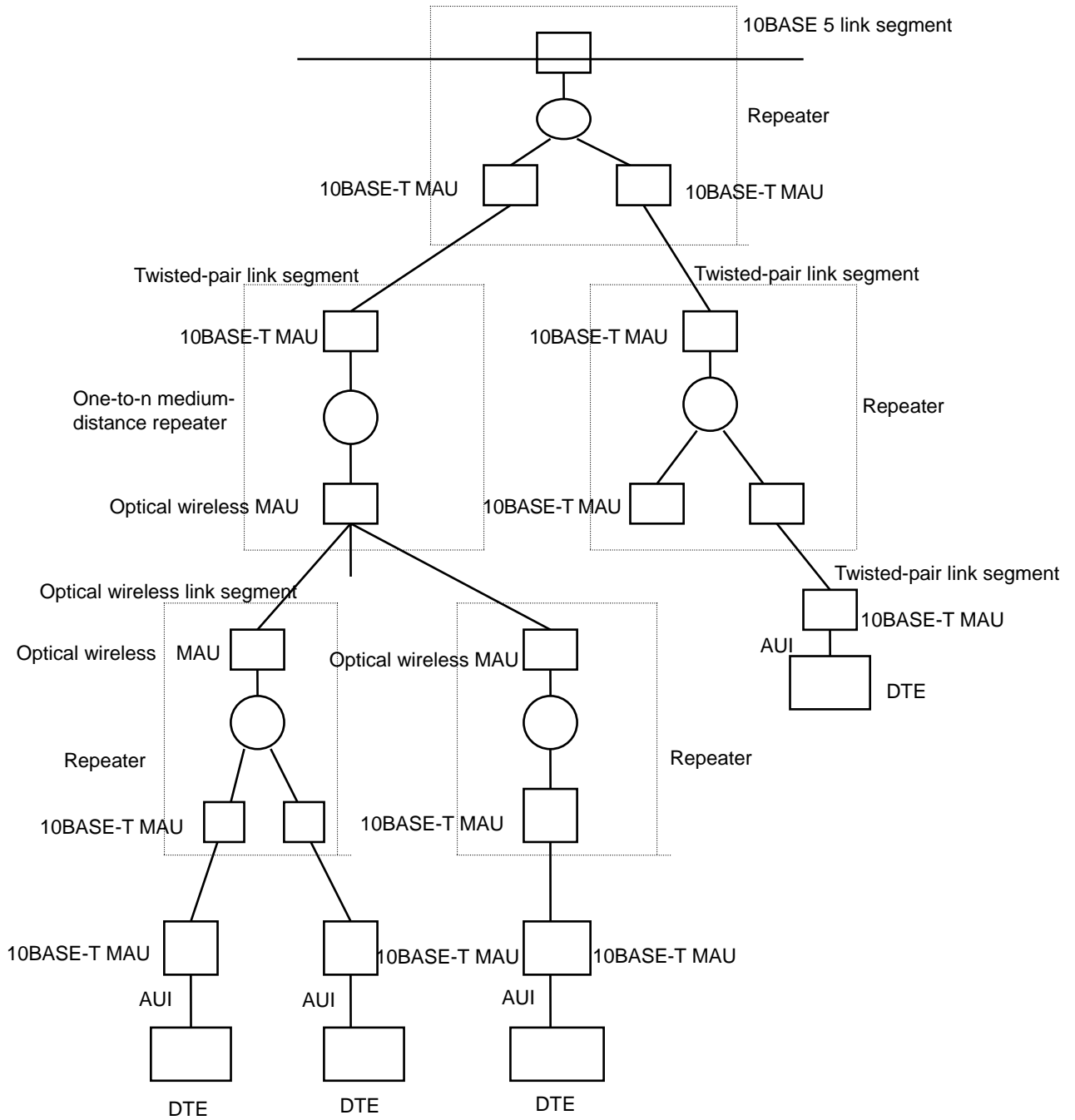

Fig. 4-2 Typical topology of a one-to-n medium-distance system

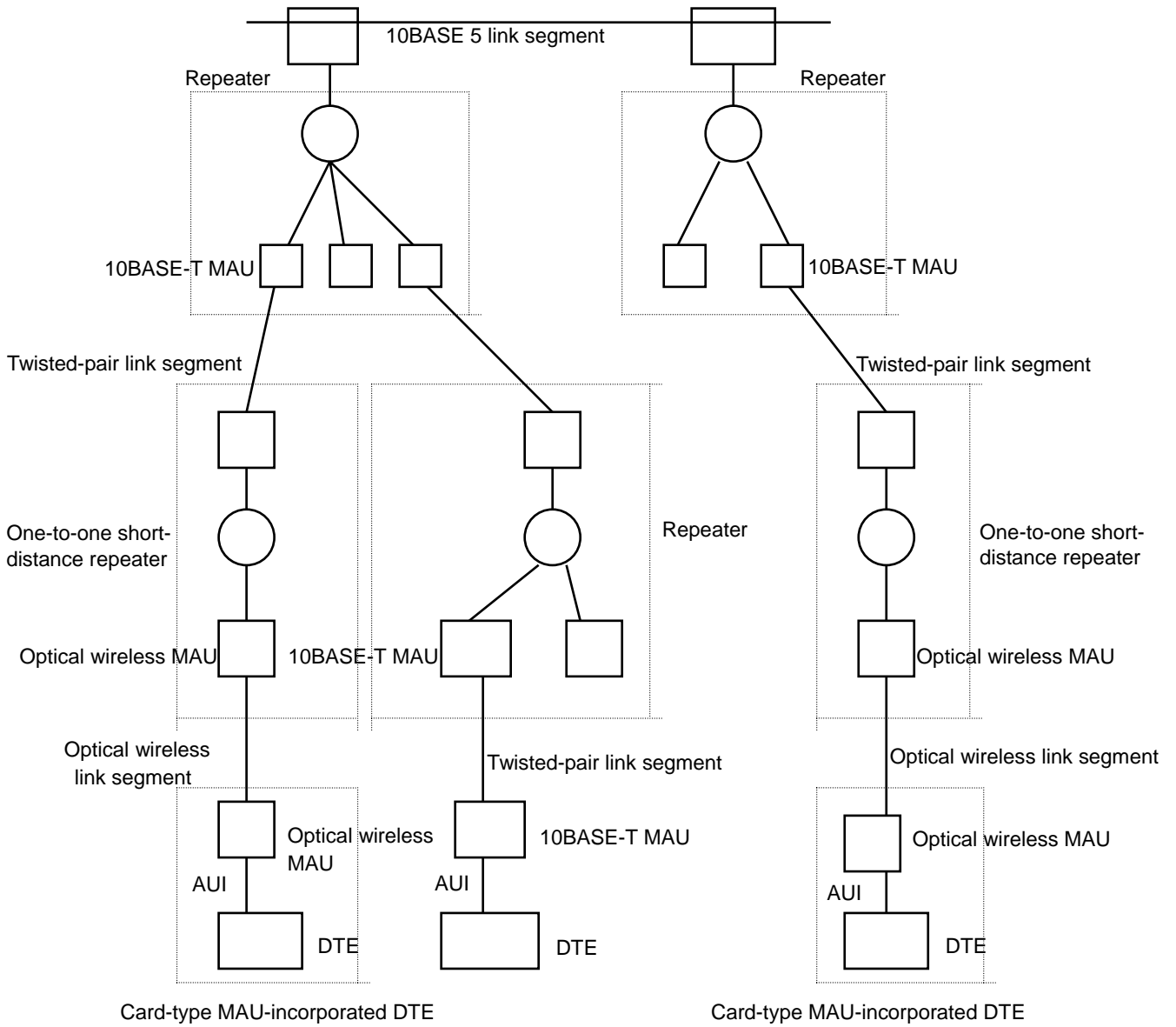

Fig. 4-3 Typical topology of a one-to-one short-distance system

Table 4-1 Specifications of each component

		Long-distance system	Medium-distance system		Short-distance system	
		One-to-one long-distance repeater	One-to-n medium-distance repeater	One-to-one medium-distance repeater	One-to-one short-distance repeater	Card-type MAU-incorporated DTE interface (PC card V2.1)
Medium access method		CSMA/CD				
Communication method		Frame sync, full duplex				
Transmission distance (m)		20	5		1	
Data transfer rate		10Mbps				
Total optical output		70 mW	2 W	70 mW	140 mW	35 mW
Half angle (degree) of transmitting directivity		Horizontal 1.5 Vertical 1.5	Horizontal 360 Vertical ± 70	Horizontal 1.5 Vertical 1.5	Horizontal 30 Vertical 5	Horizontal 30 Vertical 5
External interface		10BASE-T				
10BASE-T MDI connector	Pin No.	1	RD+	/	RD+	/
		2	RD-		RD-	
		3	TD+		TD+	
		4	Power (9V)		Power (9V)	
		5	Power (9V)		Power (9V)	
		6	TD-		TD-	
		7	GND		GND	
		8	GND		GND	

Chapter 5 MAC Layer (100Mbps)

5.1 MAC Services

Section 5.1 shall conform to the provisions in Chapter 2 of the ISO/IEC 8802-3:2000.

5.2 MAC Frame Structure

Section 5.2 shall conform to the provisions in Chapter 3 of the ISO/IEC 8802-3:2000.

5.3 Media Access

Section 5.3 shall conform to the provisions in Chapter 4 of the ISO/IEC 8802-3:2000.

5.4 Layer Management

Section 5.4 shall conform to the provisions in Chapter 30 of the ISO/IEC 8802-3:2000.

5.5 MII specification and RS layer

Section 5.5 on the Medium Independent Interface (MII) specification and the Reconciliation Sublayer (RS) shall conform to the provisions in Chapter 22 of the ISO/IEC 8802-3:2000.

5.6 Repeater unit

5.6.1 Overview

The repeater unit is used to extend the physical system topology and provides for coupling multiple segments. In the case of actual optical wireless telecommunications equipment, the wired side has a 100BASE-TX connection using a RJ-45 connector. Telecommunication on the optical wireless side takes place between repeater units comprising an optical wireless media drive facing a detector. The repeater unit is defined in Chapter 27 of the ISO/IEC 8802-3:2000, which envisions a repeater device like that shown in Fig.5-1.

As defined in the ISO/IEC 8802-3:2000, AUTONEG is Optional, and optical wireless telecommunications can be implemented using a one-to-one telecommunications topology. In the case of one-to-n optical wireless topology, the unit is configured as an optical wireless device, as shown in Fig.5-2, that does not implement AUTONEG when conducting half duplex communication using light as a covalent medium.

The ISO/IEC 8802-3:2000 definition does not envision a covalent medium in a 100BASE system. It is therefore possible to use Collision Presence on the optical wireless telecommunications side that has a different protocol than on the wired side. It can even incorporate RS layer or MAC layer functionality within the repeater unit (100BASE-T

Baseband Repeater Unit) shown in Fig. 5-2 to make up an optical wireless device.

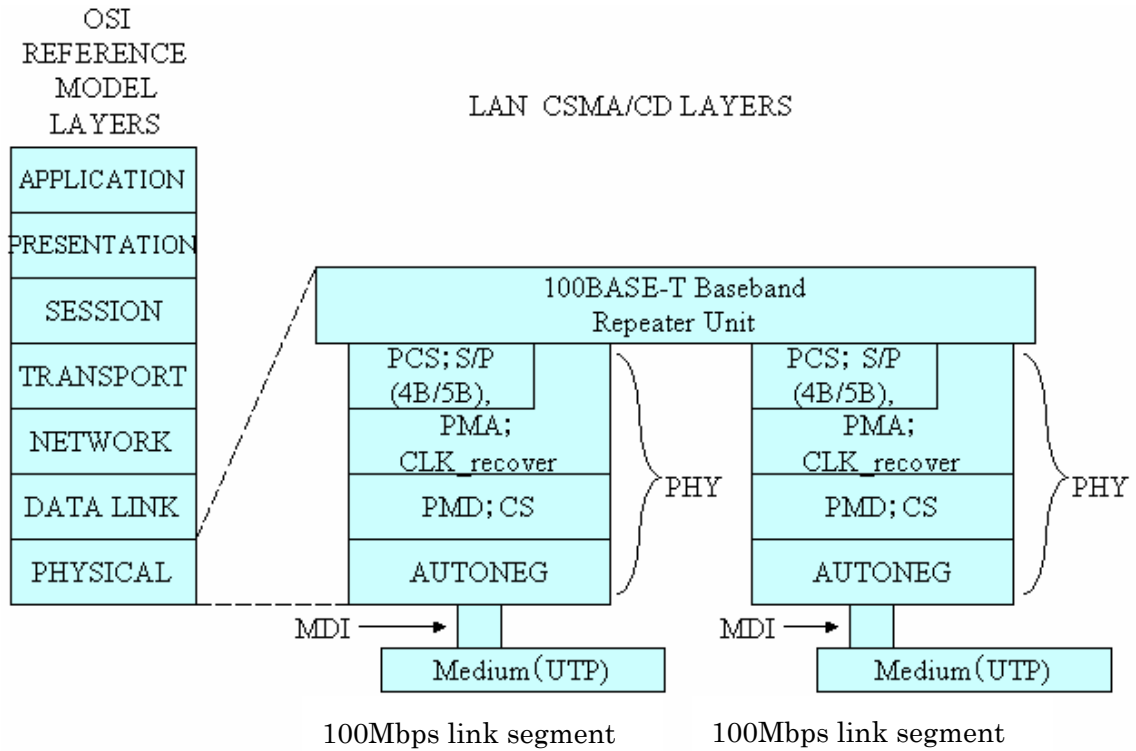

Fig. 5-1 Repeater device defined by the ISO/IEC 8802-3:2000

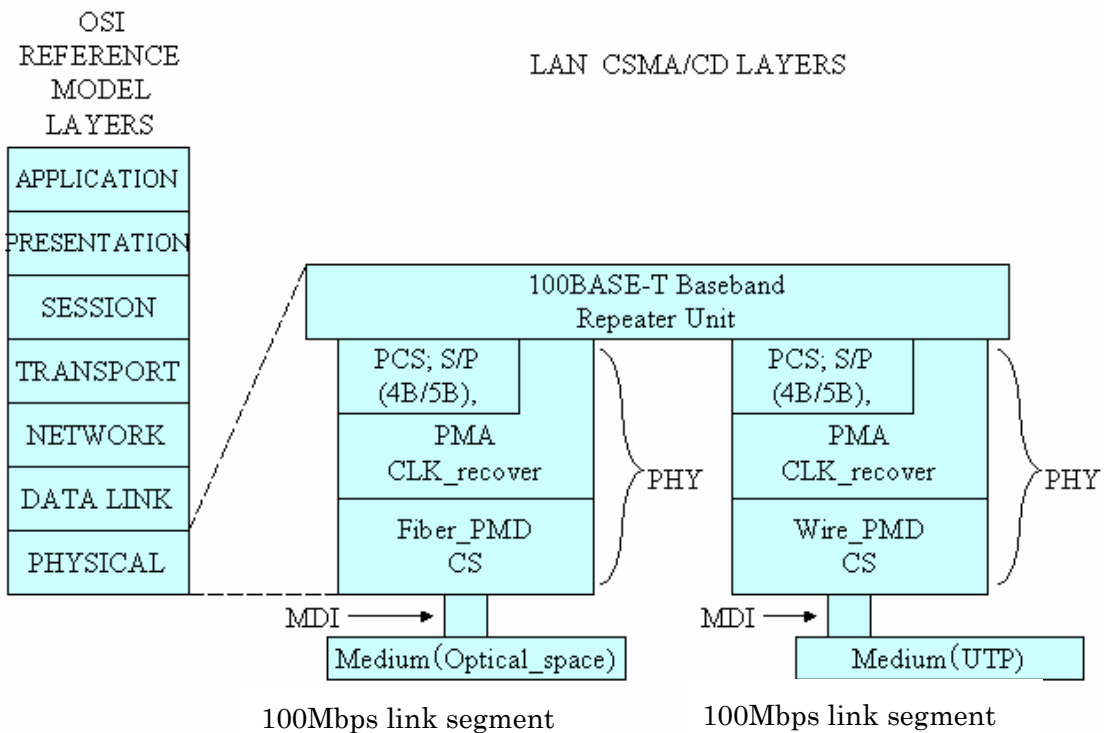

Fig. 5-2 OSI model for an optical wireless device

5.6.2 Propagation delay

According to the definition in Chapter 27 of the ISO/IEC 8802-3:2000, propagation delay by the repeater results in a delayed Collision Presence function. This means that even a repeater with very slight propagation delay is forbidden for use with more than two pairs. The optical wireless telecommunications equipment is therefore set up for use with two repeater units facing each other across the optical transmission space, and no further repeaters can be connected on the wired side. (This is not necessarily the case, however, for repeaters that incorporate a MAC layer and are configured as bridges.)

Chapter 6 Physical Layer (PHY) and Optical Wireless Baseband Medium (100Mbps)

6.1 Scope

6.1.1 Overview

Chapter 6 defines the functional, electrical, and optical characteristics of the 100Mbps baseband optical wireless type physical layer (PHY) and the specific baseband medium for use with the PHY. The relationship of the provisions of the 100Mbps baseband optical wireless type to the OSI reference model of the ISO and CSMA/CD LAN model of the ISO/IEC 8802-3:2000 is shown in Fig. 1 of Chapter 1. The purpose of the PHY is to provide a simple, inexpensive, and flexible means of attaching devices to the medium.

The provisions of Chapter 6 are based on those of Chapters 1 through 4, 21, 22, and 24 through 31 of the ISO/IEC 8802-3:2000.

The physical layer and baseband medium specification is aimed primarily at indoors and outdoors use within the range of an unobstructed view, and is expected to be applied to networks whose transmission areas cover from about one meter to several kilometers.

Simplicity in installation and reconfiguration is allowed by use of the optical wireless type physical layer and baseband medium. Moreover, since light beams are blocked at walls and are attenuated after passing through exterior windows, the characteristics of the optical system include the ability to substantially reduce the possibility of interference in communications and external wiretapping.

On the other hand, the safety regulations on photoradiation are under review by the Technical Committee TC-76 of the IEC. A standard has been established as IEC 60825-1 Edition 1.2. This standard will comply with this standard in methods of measurement and classification.

6.1.1.1 Physical Layer

The PHY (Physical Layer Device) has the following general characteristics:

- (1) The physical layer on one side can connect the Reconciliation Sublayer to an optical wireless link, as defined below, by means of a Media Independent Interface. The physical layer on the other side has a wired connection to the UTP cable by means of a MDI connector according to the provisions in the ISO/IEC 8802-3:2000.
- (2) Supports message traffic at a data rate of 100Mbps.
- (3) The Physical Coding Sublayer (PCS) encodes a signal received from the MII in 4B/5B coding. This has the idle code group and control code group added, and is serialized, then converted to Non-Return to Zero Inverted (NRZI) format at the Physical Media

Attachment (PMA), and sent on to the next Physical Media Dependent (PMD) layer. The PCS and PMA layers conform to provisions in Chapter 24 of the ISO/IEC 8802-3:2000.

- (4) The PMD layer in the physical layer on the wired side is based on the 100BASE-TX PMD standard that is defined in Chapter 25 of the ISO/IEC 8802-3:2000.
- (5) The PMD layer in the physical layer on the optical circuit side is based on the 100BASE-FX PMD standard that is defined in Chapter 26 of the ISO/IEC 8802-3:2000. The topologies that it supports are the one-to-one and the one-to-n optical wireless topologies. The PMD (including the Media Dependent Interface (MDI)), is implemented with a signal format matching the topology used in the drive method for the optical wireless emitter-receiver element.
- (6) Implementation of the AUTONEG given in the model described in Chapter 28 of the ISO/IEC 8802-3:2000 can be realized between optical wireless devices, and that implementation can be put into effect.

6.1.1.2 Optical wireless media

The physical medium used in the 100Mbps optical wireless system is envisioned as light with a wavelength ranging from 680 to 1600 nm. The light-emitting elements used are LED or LD and photo-receiving elements are PD or APD. However, this does not preclude new emitter and detector elements from being developed and adopted.

6.1.2 Definitions

This section defines the terminology specific to the physical layers, repeater units, and other such components of 100Mbps baseband optical wireless systems.

(1) Bit Time (BT)

The duration of one bit symbol (1/BR).

(2) Collision

An undesirable condition that results from concurrent transmission from multiple signal sources.

(3) Media Independent Interface (MII)

An electrical interface needed to transport service primitives from the MAC layer to the physical layer of the optical wireless system. It provides a connection between the RS layer and PCS layer.

(4) Reconciliation Sublayer (RS)

Converts service primitives from the MAC layer to MII signals.

(5) Physical Layer Device (PHY)

Comprised of the driver for the physical media (PMD) and the signal detector (PMA), together with the modulator-demodulator (PCS). It provides logical signals to the data link layer (MAC) through the MII and RS.

In a 100Mbps optical wireless device, there is one set each of the optical wireless type PHY and the wired PHY. Different media link to the PHY appropriate to those media, thus composing a repeater device.

(6) Simplex link segment

A wireless path between two optical wireless PHYs, including terminal connectors.

(7) Optical wireless link

Optical wireless link segment and two PHYs connected to it.

(8) Optical wireless link segment

An optical space for the purpose of connecting two PHYs.

(9) 100BASE-OPT

The general term for signal exchange systems suited to transmission across optical spaces applying the 100BASE-FX signal format defined in Chapter 24 and 26 of the ISO/IEC 8802-3:2000.

6.1.3 Application perspective

This section states broad objectives and assumptions underlying the specifications defined through Chapter 6.

- (1) Provide the physical means for communication between LAN Data Link Layer Entities.
- (2) Provide a communication channel with a mean bit error rate, at the physical layer service interface, of 10^{-8} or lower.
- (3) Provide for ease of installation and maintenance.
- (4) Ensure that fairness of DTE access is not compromised.
- (5) Provide for low-cost networks.

6.1.4 PHY topologies

The 100Mbps baseband optical wireless type PHY uses the MII signal format to communicate with the RS and MAC layers, which are higher layers. It communicates by dispatching signals through the optical wireless space, which is its physical medium. This makes it possible to structure a DTE within the network system. Examination of actual cases of use, however, will show that equipment equipped with 100BASE-TX ports are by far the most widely used as telecommunications terminals. As seen in Fig. 5-1 and Fig. 5-2 in section

5.6, the PHY on one side of the repeater (Repeater Unit) is configured as a 100BASE-TX (wired) port, and the PHY on the opposite side is configured as a 100BASE-FX (optical wireless) port. A topology that places one repeater (Repeater Unit) facing another in this way to communicate is easy to use. Therefore, the physical layer (PHY) topology also conforms with the PHY connection of the Repeater Unit described in Chapter 27 of the ISO/IEC 8802-3:2000. As stated in 5.6.1, however, it is possible to incorporate a RS layer internally in order to detect collision at the optical wireless communication side, or to incorporate a MAC layer for the purpose of a bridge configuration as described in 5.6.2.

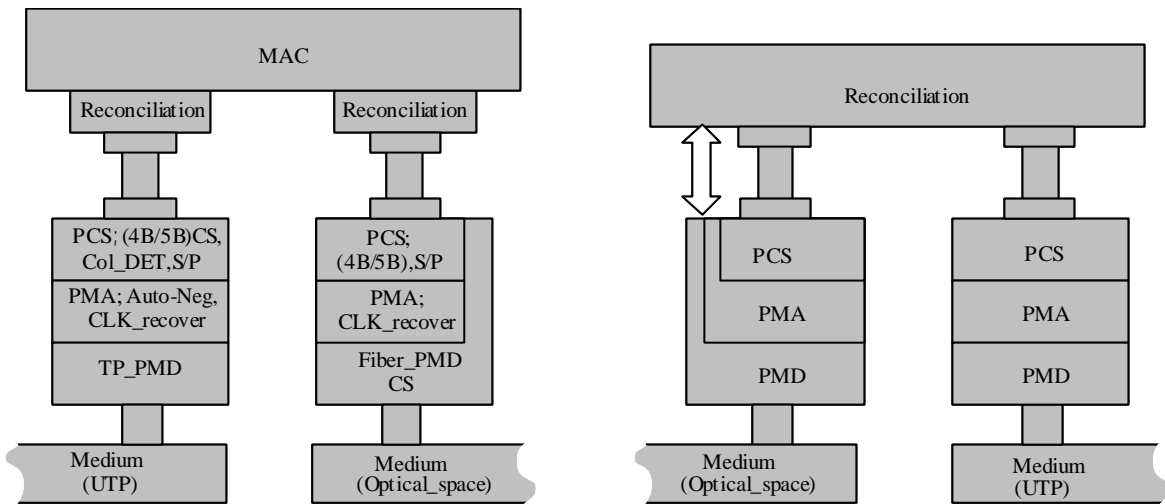

Fig. 6-1 Example of Optical Wireless System configuration

6.1.4.1 100BASE-TX connections by RJ-45 connector on the wired side

This is defined in Chapter 25 of the ISO/IEC 8802-3:2000, and the wiring inside the connector follows Table 25-2 (UTP MDI contact assignments) in that chapter.

6.1.4.2 Configuration of PHY on the optical wireless side based on 100BASE-FX

The standard for this is the physical layer defined in Chapter 26 of the ISO/IEC 8802-3:2000. However, this does not preclude the inclusion of differences that are necessary because of telecommunications system configuration.

6.2 Functional specifications of optical wireless type PHY

The 100 Mbps baseband optical wireless type PHY offers a means by which signals from the MAC layer that are joined by means of the MII signal format as well as associated interlayer messages are coupled to the optical wireless link segment. The optical wireless type PHY provides the following functional capabilities to handle message flow on the optical wireless link segment that is formed with other, facing optical wireless type PHYs.

- (1) Transmit function

Provides the ability to transfer 100BASE-FX signal data as described in 6.1.1.1, or compatible communications signals, from the PMD layer to the light-emitting circuit. While not transmitting signal data, the PHY maintains an idle signal or a compatible signal status.

(2) Receive function

Provides the ability to transfer signal data from the photo-detecting circuit to the PMD layer. It is possible to implement a transmission function that causes the PHY to transmit an idle signal status by means of the MII when it is not receiving signal data, and that implementation can be put into effect.

(3) Loopback function

Provides the ability to implement a transmission function that transfers 100BASE-FX signal data or compatible communications signals from the transmitter circuit to the receiver circuit when it is not receiving signal data from the photo-detecting circuit, and that implementation can be put into effect.

(4) Collision Presence function

Provides the ability to detect the simultaneous occurrence of 100BASE-FX signal data and 100BASE-TX signal data between the optical wireless side PHY and the wired side PHY, and reports this occurrence as a collision.

(5) Link confirmation function

Provides the ability to detect an optical wireless type PHY that is facing the optical wireless type PHY and uses a repeater function to send an Idle signal to the PHY on the wired side, thus notifying the DTE that a link has been established.

6.2.1 PHY functions

The PHY provides the various functions of Transmit, Receive, Loopback, Collision Presence, Jam, and Link Confirmation. In implementing the Link Confirmation function, the PHY that is connected to the circuit on the wired side is controlled by the PHY that is connected to the optical wireless circuit. The PHY layer signal is sent to the RS and MAC layers in MII signal format. The signal processed by the MAC and RS layers is also sent to the PHY layer in MII signal format, and transmitted.

The following mainly describe the PHY on the optical wireless side.

6.2.1.1 Transmit function requirements

The requirements conform to the provisions of 22.2.2.1, 3, and 4 of the ISO/IEC 8802-3:2000. However, the transmission clock signal is defined according to the provisions of 22.2.2.1 in the ISO/IEC 8802-3:2000, the transmission-enable signal according to 22.2.2.3, and the

transmission data according to 22.2.2.4.

6.2.1.2 Receive function requirements

The requirements conform to the provisions of 22.2.2.2, 6, and 7 of the ISO/IEC 8802-3:2000. However, the reception clock signal is defined according to the provisions of 22.2.2.2 in the ISO/IEC 8802-3:2000, the reception confirmation signal in 22.2.2.6, and the reception data in 22.2.2.7.

6.2.1.3 Error handling function requirements

The requirements conform to the provisions of 22.2.2.5 and 8 of the ISO/IEC 8802-3:2000. However, transmission error handling conforms to the provisions in 22.2.2.5, and reception error handling to the provisions in 22.2.2.8.

6.2.1.4 Collision presence (COL) function requirements

The requirements conform to the provisions of 22.2.2.10 of the ISO/IEC 8802-3:2000.

6.2.1.5 Carrier sensing function requirements

The requirements conform to the provisions of 22.2.2.9 of the ISO/IEC 8802-3:2000.

6.2.2 Management interface

The requirements conform to the provisions of 22.2.2.11 and 12 of the ISO/IEC 8802-3:2000. The management interface is a simple two-wire serial interface. The data clock conforms to the provisions of 22.2.2.11 and bidirectional data to the provisions of 22.2.2.12.

6.2.3 Frame structure

The format of the signal input and output from MII conforms to the provisions of 22.2.3 of the ISO/IEC 8802-3:2000.

6.3 Optical signal provisions

The code group conforms to the provisions in 24.2.2.1 and Table 24-1 in the ISO/IEC 8802-3:2000. MAC frames are assigned to the optical signal conforming to the provisions in 24.2.2.2 and 4 and in Figures 24-5 and 6.

6.3.1 Transmission function

6.3.1.1 Light emission

A strong signal is emitted when the logical level of the PMD is "1" and a weak signal or no signal is emitted when it is "0."

6.3.1.2 Peak emission wavelength

The recommended peak emission wavelength on the transmitting side lies within the 680–1600 nm range. However, this provision does not preclude waveforms outside this range

from being used.

6.3.1.3 Output power

For indoor applications, Class 1 as provided for in IEC 60825-1 Edition 1.2 is recommended, and for outdoor applications, Class 1 or 1M is recommended.

6.3.1.4 MII Idle (Data Valid signal)

An IDL signal inputted from an optical wireless circuit is starting by a "J" or "K" symbol and will change into a preamble signal. At that time, the PHY will output a MII signal in the form of a DV (Data Valid) signal. The DV signal will terminate when a "T" or "R" symbol is inputted.

6.3.1.5 Link confirmation signal

A function for sending notification that a link has been established by transmitting an idle signal to the PHY on the wired side, or by some other such means, will be needed when an optical wireless type PHY detects another optical wireless type PHY facing it.

6.3.2 Receive function

6.3.2.1 Light sensing

A logic of "1" is output to the PMD when a strong signal is detected, and a logic of "0" is output when a weak signal is detected.

6.3.2.2 Receiving sensitivity

This is displayed in terms of irradiance (unit: $\mu\text{W}/\text{cm}^2$) or light reception power (unit: dBm).

6.3.2.3 Idle input operation

The PMD must identify an idle state when it detects that all 5B symbol bits are "1" or in other words, when the NRZI signal has changed in each bit for five or more consecutive bits. It is sufficient if the signal status of the optical wireless signal communicates non-signal status.

Chapter 7 Examples of Systems to be Implemented

7.1 One-to-one System

A one-to-one system is used when conducting network expansion using an optical wireless medium. Functions like those shown below are available, as shown in the one-to-one model with AUTONEG in Fig. 7-1.

- The 100BASE-TX interface on the wired side is converted to the 100BASE-OPT optical wireless interface. Conversely, the 100BASE-OPT is also converted to 100BASE-TX.
- The 100BASE-TX interface on the wired side and the 100BASE-OPT optical wireless interface can both implement AUTONEG.

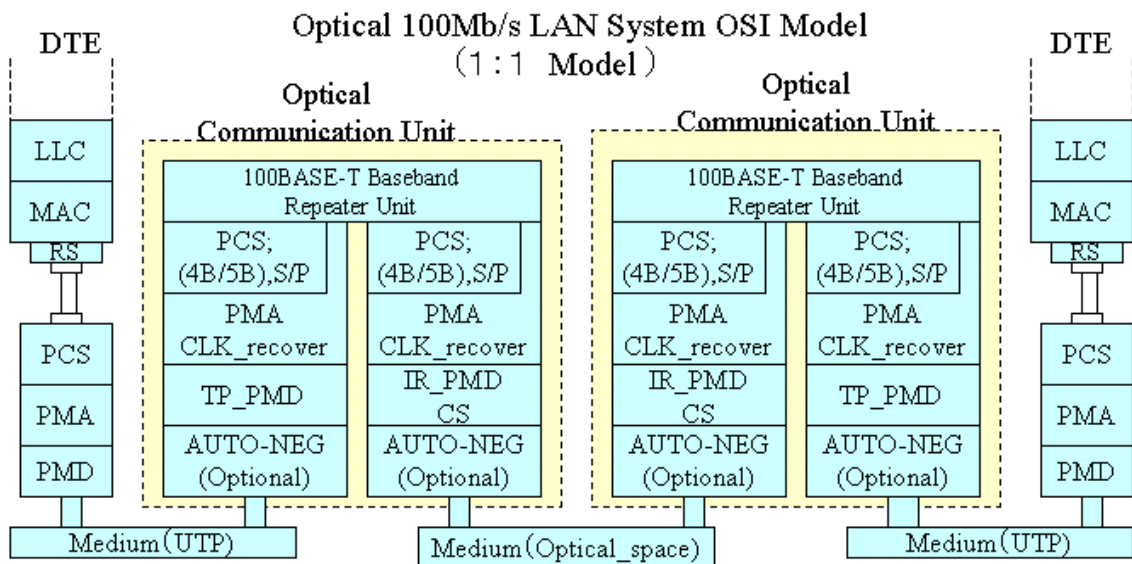

Fig. 7-1 Typical topology of a one-to-one system

The PCS, PMA, and AUTONEG defined for 100BASE-FX are applicable without any modification to 100BASE-OPT. The optical PMD converts NRZI data from the PMA into optical signals. It also converts NRZI optical signals into electrical signals.

7.2 One-to-n System

This is a typical one-to-n system applicable to medium distances (a few meters apart). The components comprising this system are a one-to-n repeater and a one-to-n satellite unit.

In either of these components, a signal that is going from the 100BASE-TX wired side to the optical circuit side passes through a wired PHY configuration to a Physical Coding Sublayer (PCS). There it undergoes 4B/5B encoding and has an idle code group and control code group

attached. The serialized signal is converted to Non-Return to Zero Inverted (NRZI) format by the Physical Media Attachment (PMA), and sent on to the next Physical Media Dependent (PMD) layer. In the PMD, including the Media Dependent Interface (MDI), a drive signal is generated with the FX signal format, which is suited to drive the optical wireless emitter-receiver element. These components comprise a 100BASE Baseband Repeater Set. These functions integrate outgoing and incoming pairs. The former are mainly installed on ceilings, walls, and so on, while the latter are usually placed on desktops.

By using a one-to-n repeater installed on the ceiling or a similar position and more than one one-to-n satellite units installed on a desk or similar position, a twisted-pair link segment on the desk can be easily connected with other twisted-pair link segments (half duplex communication).

The one-to-n satellite unit has a directional optical unit, and more than one repeater can be installed in a single space. On the other hand, the one-to-n repeater has wider directivity to allow connection with more than one one-to-n satellite unit.

A typical topology of this system is illustrated in Fig. 7-2.

A one-to-n repeater implements Collision Presence for infrared FX signals in covalent media by means of the Reconciliation Sublayer (RS).

Therefore, signals that come from a certain one-to-n satellite unit over an optical wireless link segment by means of this Reconciliation Sublayer, and are input to a repeater, are sent through that repeater unit to the 100BASE-TX side.

Subsequently, the signal retained by the one-to-n medium-distance repeater is also sent to the optical wireless link segment, and is received by another one-to-n satellite unit.

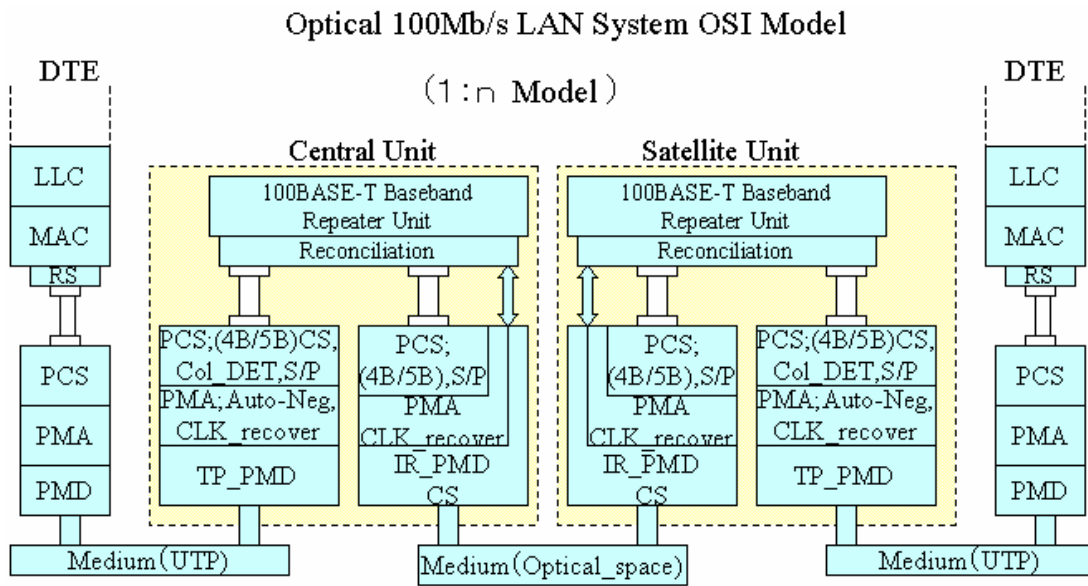

Fig. 7-2 Typical topology of a one-to-n system

Chapter 8 Beam Profile of the Optical Wireless Medium

Telecommunications equipment should be located in ways that do not affect the equipment that comprise neighboring segments.

An advantage of optical wireless systems is that segments can be compartmentalized, even within the same room, by means of beam profiles. Multiple segments can be laid out adjoining each other to enable the connection of extremely large numbers of telecommunications terminals (personal computers and so on). Fig. 8-1 shows the representation of a typical beam profile in an indoor optical wireless LAN.

For this reason, the equipment installers should be shown the light emission profiles of the various items of equipment and informed about the range within which that equipment can affect the photo-detecting devices of other equipment. This information should be disclosed.

The area of a light emission profile can be represented in terms of the full width at half maximum from the center, or in terms of irradiance (in units of $\mu\text{W}/\text{cm}^2$), or in terms of light reception power (in units of dBm), and so on. The method of representation is left to the discretion of the manufacturer. As described in 3.3.1.3, however, it is recommended that output power be Class 1 or Class 1M as specified in Edition 1.2 of IEC 60825-1.

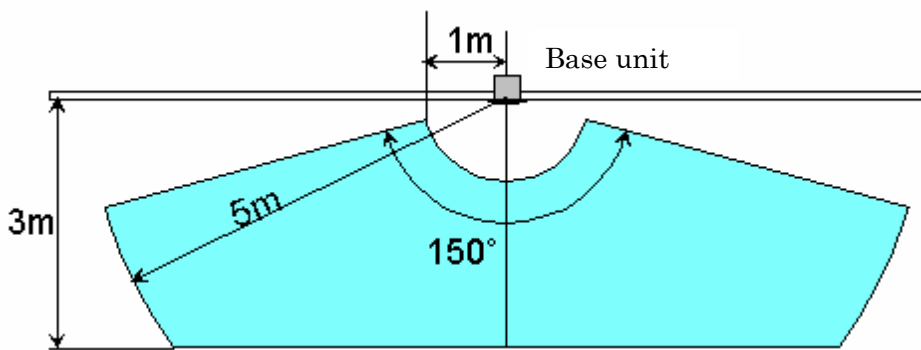

Fig. 8-1 Typical beam profile representation

Chapter 9 MAC Layer (1000 Mbps)

9.1 MAC Services

The requirements conform to the provisions of Chapter 2 of the ISO/IEC 8802-3:2000.

9.2 MAC Frame Structure

The requirements conform to the provisions of Chapter 3 of the ISO/IEC 8802-3:2000.

9.3 Media Access

The requirements conform to the provisions of Chapter 4 of the ISO/IEC 8802-3:2000.

9.4 Layer Management

The requirements conform to the provisions of Chapter 30 of the ISO/IEC 8802-3:2000.

9.5 GMII specification and RS layer

The requirements on the Gigabit Media Independent Interface (GMII) specification and the Reconciliation Sublayer (RS) conform to the provisions of Chapter 35 of the ISO/IEC 8802-3:2000.

9.6 Repeater Unit

9.6.1 Overview

The repeater unit is used to extend the physical system topology and provides for coupling multiple segments. In the case of actual optical wireless telecommunications equipment, the wired side has a 1000BASE-TX (wired) port connection. Telecommunication on the optical wireless side takes place between repeater units comprising an optical wireless media drive facing a detector. The repeater unit is defined in Chapter 41 of the ISO/IEC 8802-3:2000, which envisions an optical wireless device like that shown in Fig. 9-1.

As defined in the ISO/IEC 8802-3:2000, AUTONEG is required and implementation is also possible in the case of optical wireless telecommunications. Blockage unavoidably occurs given the characteristics of optical wireless systems. The telecommunications failure caused by such factors can be addressed using methods different from those used on the wired side. The repeater unit shown in the figure (1000BASE-T Baseband Repeater Unit) can even incorporate RS layer or MAC layer functionality internally, to make up an optical wireless device.

9.6.2 Propagation delay

According to the definition in Chapter 41 of the ISO/IEC 8802-3:2000, propagation delay by the repeater results in a delayed Collision Presence function. This means that even a repeater with very slight propagation delay is forbidden for use with more than two pairs. The optical wireless telecommunications equipment is therefore set up for use with two repeater units facing each other across the optical transmission space, and no further repeaters can be connected on the wired side. (This is not necessarily the case, however, for repeaters that incorporate a MAC layer and are configured as bridges.)

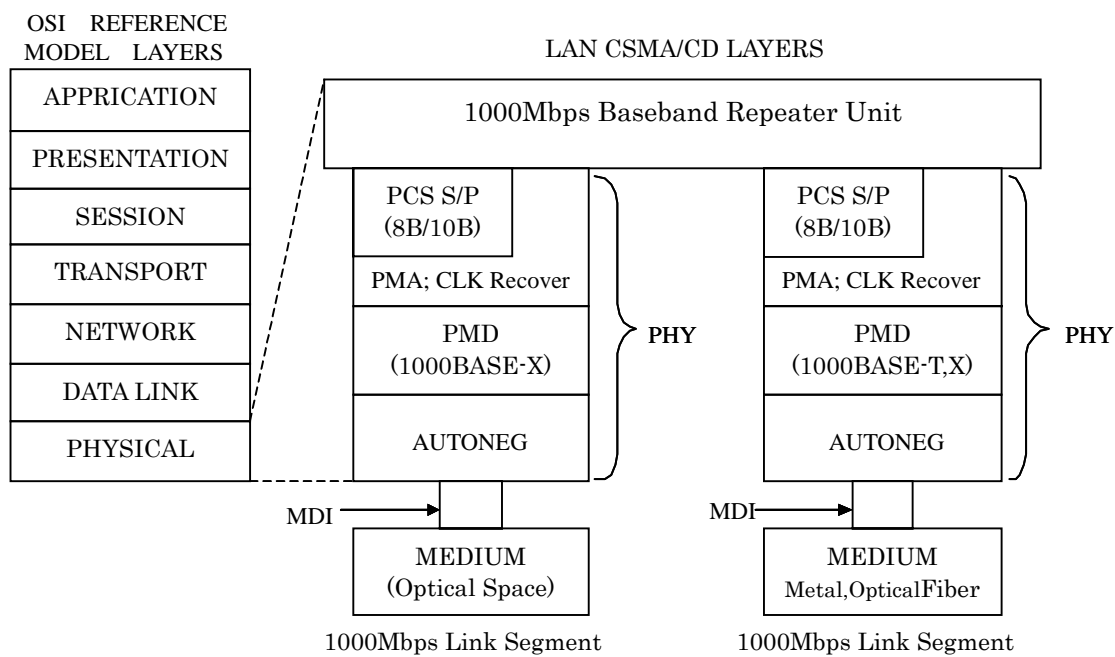

Fig. 9-1 OSI model for an optical wireless device

Chapter 10 Physical Layer (PHY) and Optical Wireless Baseband Medium (1000 Mbps)

10.1 Scope

10.1.1 Overview

Chapter 10 defines the mechanical, electrical, and optical characteristics of the 1000 Mbps baseband optical wireless type physical layer (PHY) and the specific baseband medium for use with the PHY. The purpose of the PHY is to provide a simple, inexpensive, and flexible means of attaching devices to the medium.

The provisions of Chapter 10 are based on those of Chapters 1 through 4, 30 through 31, 34 through 37, and 40 through 43 of the ISO/IEC 8802-3:2000.

The physical layer and baseband medium specification is aimed primarily at indoors and outdoors use within the range of an unobstructed view, and is expected to be applied to networks whose transmission areas cover from about one meter to several kilometers.

Simplicity in installation and reconfiguration is allowed by use of the optical wireless type physical layer and baseband medium. Moreover, since light beams are blocked at walls and are attenuated after passing through exterior windows, the characteristics of the optical system include the ability to substantially reduce the possibility of interference in communications and external wiretapping.

On the other hand, the safety regulations on photoradiation are under review by the Technical Committee TC-76 of the IEC. A standard has been established as IEC 60825-1 Edition 1.2. This standard will comply with this standard in methods of measurement and classification.

10.1.1.1 Physical Layer

The PHY (Physical Layer Device) has the following general characteristics:

- (1) The physical layer on one side can connect the Reconciliation Sublayer to an optical wireless link, as defined below, by means of a Gigabit Media Independent Interface. The physical layer on the other side has a wired connection to a UTP cable, multi mode fiber, single mode fiber, and balanced shielded cable by means of a MDI connector according to the provisions of the ISO/IEC 8802-3:2000.
- (2) Supports message traffic at a data rate of 1000 Mbps.
- (3) The Physical Coding Sublayer (PCS) encodes a signal received from the GMII in 8B/10B coding. This has the idle code group and control code group added, and is serialized, then converted to Non-Return to Zero (NRZ) format at the Physical Media Attachment (PMA), and sent on to the next Physical Media Dependent (PMD) layer.

The PCS and PMA layers conform to provisions in Chapter 36 of the ISO/IEC 8802-3:2000.

- (4) The PMD layer in the physical layer on the wired side is based on the 1000BASE-T, X PMD standard that is defined in Chapter 38 to 40 of the ISO/IEC 8802-3:2000.
- (5) The PMD layer in the physical layer on the optical circuit side is based on the 1000BASE-X PMD standard that is defined in Chapter 38 of the ISO/IEC 8802-3:2000. The topologies that it supports are the one-to-one and the one-to-n optical wireless topologies. The PMD (including the Media Dependent Interface (MDI)), is implemented with a signal format matching the topology used in the drive method for the optical wireless emitter-receiver element.
- (6) Implementation of the AUTONEG given in the model described in Chapter 37 of the ISO/IEC 8802-3:2000 can be realized between optical wireless devices, and that implementation can be put into effect.

10.1.1.2 Optical wireless media

The physical medium employed with a 1000 Mbps optical wireless system is envisioned as light with a wavelength ranging from 680 to 1600 nm. The light-emitting elements used are LED or LD and photo-detecting elements are PD or APD. However, this does not preclude new emitter and detector elements from being developed and adopted.

10.1.2 Definitions

This section defines the terminology specific to the physical layers, repeater units, and other such components of 1000 Mbps baseband optical wireless systems.

(1) Multi Mode Fiber (MMF)

Fiber optic cable with a large core diameter that is designed to support multiple modes of light propagation.

(2) Single Mode Fiber (SMF)

Fiber optic cable with a small core diameter designed to support a single mode of light propagation. It has a large transmission bandwidth and is suited to long-distance transmission.

(3) Gigabit Media Independent Interface (GMII)

Electrical interface needed to transport service primitives from the MAC layer to the optical wireless link and provides a connection between the RS layer and PCS layer.

(4) NRZ

Coding format that encodes the "0" and "1" logic values each with a pulse width of one. In positive logic, the logic value "0" is coded as LOW level and the logic value "1" is coded as

HIGH level.

10.1.3 Application perspective

This section states broad objectives and assumptions underlying the specifications defined through Chapter 10.

10.1.3.1 Objectives

- (1) Provide the physical means for communication between LAN Data Link Layer Entities.
- (2) Provide a communication channel with a mean bit error rate, at the physical layer service interface, of 10^{-12} or lower under normal communications conditions free of external disturbances such as effects caused by rainfall, snowfall, fog, sunlight, and so on.
- (3) Provide for easy installation and maintenance.
- (4) Ensure that fairness of DTE access is not compromised.
- (5) Provide for low-cost networks.

10.1.4 PHY topologies

The 1000Mbps baseband optical wireless type PHY uses the GMII signal format to communicate with the RS and MAC layers, which are higher layers. It is possible to constitute a DTE in the network system by communicating these signals through the optical wireless space which is a physical medium. Considering of actual use, however, a topology that places one repeater (Repeater Unit) facing another to communicate, where the PHY on one side of repeater (Repeater Unit) is configured as a 1000BASE-TX (wired) port shown in Fig.10-1, is easy to use. The physical layer (PHY) topology therefore also conforms with the PHY connection of the Repeater Unit described in Chapter 41 of the ISO/IEC 8802-3:2000. It is possible, however, to incorporate a RS layer as a measure to counter communication failures caused by shielding or other such factors on the optical wireless communications side, as stated in 9.6.1, and it is also possible to incorporate a MAC layer in order to configure a bridge, as stated in 9.6.2.

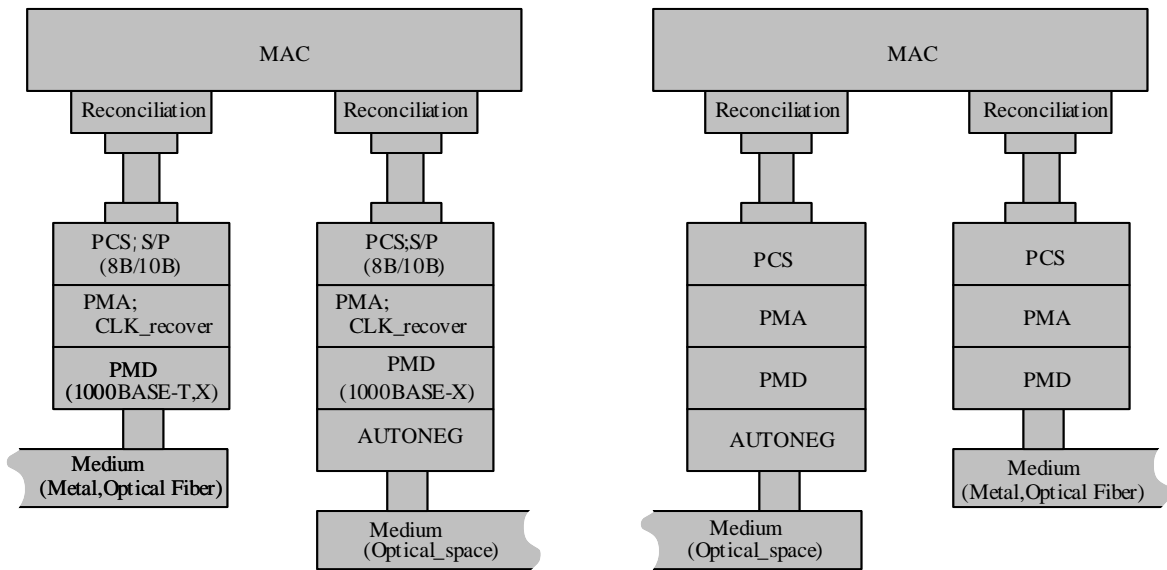

Fig. 10-1 Example of Optical Wireless System configuration

10.1.4.1 1000BASE-T connections by RJ-45 connector on the wired side

This is defined in Chapter 40 of the ISO/IEC 8802-3:2000, and the wiring inside the connector follows Table 40-12 (Assignment of PMA signal to MDI and MDI-X pin-outs) in that chapter.

10.1.4.2 1000BASE-X connections on the wired side

This conforms to the provisions defined in Chapters 38 and 39 of the ISO/IEC 8802-3:2000.

10.1.4.3 Configuration of PHY on the optical wireless side based on 1000BASE-X

The standard for this is the physical layer defined in Chapter 38 of the ISO/IEC 8802-3:2000. However, this does not preclude the inclusion of differences that are necessary because of communication system configuration.

10.2 Functional Specifications of Optical Wireless Type PHY

The 1000 Mbps baseband optical wireless type PHY offers a means by which signals from the MAC layer that are joined by means of the GMII signal format as well as associated interlayer messages are coupled to the optical wireless link segment. The optical wireless type PHY provides the following functions to handle message flow on the optical wireless link segment that is formed with other, facing optical wireless type PHYs.

(1) Transmit function

Provides the ability to transfer 1000BASE-X signal data as described in 10.1.1.1, or compatible communications signals, from the PMD layer to the light-emitting circuit.

While not transmitting signal data, the PHY maintains an idle signal or a compatible signal status.

(2) Receive function

Provides the ability to transfer signal data from the photo-detecting circuit to the PMD layer. It is possible to implement a transmission function that causes the PHY to transmit an idle signal status by means of the GMII when it is not receiving signal data, and that implementation can be put into effect.

(3) Loopback function

Provides the ability to implement a transmission function that transfers 1000BASE-X signal data or compatible communications signals from the transmitter circuit to the receiver circuit when it is not receiving signal data from the photo-detecting circuit, and that implementation can be put into effect.

(4) Collision Presence function

Provides the ability to detect the simultaneous occurrence of 1000BASE-X signal data and 1000BASE-T signal data between the optical wireless side PHY and the wired side PHY, and reports this occurrence as a collision.

(5) Link confirmation function

Provides the ability to detect an optical wireless type PHY that is facing the optical wireless type PHY and uses a repeater function to send an Idle signal to the PHY on the wired side, thus notifying the DTE that a link has been established.

10.2.1 PHY functions

The PHY provides the various functions of Transmit, Receive, Loopback, Collision Presence, Jam, and Link Confirmation. In implementing the Link Confirmation function, the PHY that is connected to the circuit on the wired side is controlled by the PHY that is connected to the optical wireless circuit. The PHY layer signal is sent to the RS and MAC layers in GMII signal format. The signal processed by the MAC and RS layers is also sent to the PHY layer in GMII signal format, and transmitted.

The following mainly describe the PHY on the optical wireless side.

10.2.1.1 Transmit function requirements

The requirements conform to the provisions of 35.2.2.1, 3, and 4 of the ISO/IEC 8802-3:2000. However, the transmission clock signal is defined according to the provisions of 35.2.2.1 in the ISO/IEC 8802-3:2000, the transmission-enable signal according to 35.2.2.3, and the transmission data according to 35.2.2.4.

10.2.1.2 Receive function requirements

The requirements conform to the provisions of 35.2.2.2, 6, and 7 of the ISO/IEC 8802-3:2000. However, the reception clock signal is defined according to the provisions of 35.2.2.2 in the ISO/IEC 8802-3:2000, the reception confirmation signal in 35.2.2.6, and the reception data in 35.2.2.7.

10.2.1.3 Error handling function requirements

The requirements conform to the provisions of 35.2.2.5 and 8 of the ISO/IEC 8802-3:2000. However, transmission error handling conforms to the provisions in 35.2.2.5, and reception error handling to the provisions in 35.2.2.8.

10.2.1.4 Collision Presence (COL) function requirements

The requirements conform to the provisions of 35.2.2.10 of the ISO/IEC 8802-3:2000.

10.2.1.5 Carrier sensing function requirements

The requirements conform to the provisions of 35.2.2.9 of the ISO/IEC 8802-3:2000.

10.2.2 Management interface

The requirements conform to the provisions of 35.2.2.11 and 12 of the ISO/IEC 8802-3:2000. The management interface is a simple two-line serial interface. The data clock conforms to the provisions of 35.2.2.11 and bidirectional data to the provisions of 35.2.2.12.

10.2.3 Frame structure

The format of the signal input and output from GMII conforms to the provisions of 35.2.3 of the ISO/IEC 8802-3:2000.

10.2.4 Optical Signal Provisions

The code group conforms to the provisions in 36.2 and Table 36-1, 2, and 3 in the ISO/IEC 8802-3:2000. MAC frames are assigned to the optical signal conforming to the provisions in 36.2.4.18 and 4 and in Figure 36-3 and 4.

10.3.1 Transmission function

10.3.1.1 Light emission

A strong signal is emitted when the logical level of the PMD is "1" and a weak signal or no signal is emitted when it is "0."

10.3.1.2 Peak emission wavelength

The recommended peak emission wavelength on the transmitting side lies within the 680-1600 nm range. However, this provision does not preclude wavelength outside this range

from being used.

10.3.1.3 Output power

For indoor applications, Class 1 as provided for in IEC 60825-1 Edition 1.2 is recommended, and for outdoor applications, Class 1 or 1M is recommended.

10.3.1.4 GMII Idle (Data Valid signal)

An IDL signal inputted from an optical wireless circuit will be prefixed by a "S" symbol and will change into a preamble signal. At that time, the PHY will output a GMII signal in the form of a DV (Data Valid) signal. The DV signal will terminate when a "T" symbol is entered.

10.3.1.5 Link confirmation signal

A function for sending notification that a link has been established by transmitting an idle signal to the PHY on the wired side, or by some other such means, will be needed when an optical wireless type PHY detects another optical wireless type PHY facing it.

10.3.2 Receive function

10.3.2.1 Light sensing

A logic of "1" is output to the PMD when a strong signal is detected, and a logic of "0" is output when a weak signal is detected.

10.3.2.2 Receiving sensitivity

This is displayed in terms of irradiance (unit: $\mu\text{W}/\text{cm}^2$) or light reception power (unit: dBm).

10.3.2.3 Idle input operation

The PMD layer must identify an idle state when it detects a /K28.5/D5.6/ code or a /K28.5/D16.2/ code. It is sufficient if the signal status of the optical wireless signal communicates non-signal status.

Chapter 11 Installation of Devices

Communication equipment should be located in ways that do not affect the equipment that makes up neighboring segments.

An advantage of optical wireless systems is that segments can be compartmented, even within a single space, by means of beam profiles. Multiple segments can be laid out adjoining each other to enable the connection of extremely large numbers of communication terminals (personal computers and so on). Fig. 11-1 shows a typical optical wireless device installation.

For this reason, the equipment installers should be shown the light emission profiles of the various items of equipment and informed about the range within which that equipment can affect the photo-detecting devices of other equipment. This information should be disclosed.

The area of a light emission profile can be represented in terms of the full width at half maximum from the center, or in terms of irradiance (in units of $\mu\text{W}/\text{cm}^2$), or in terms of light receiving power (in units of dBm), and so on. The method of representation is left to the discretion of the manufacturer. As described in 10.3.1.3, however, it is recommended that output power be Class 1 or Class 1M as specified in Edition 1.2 of IEC 60825-1.

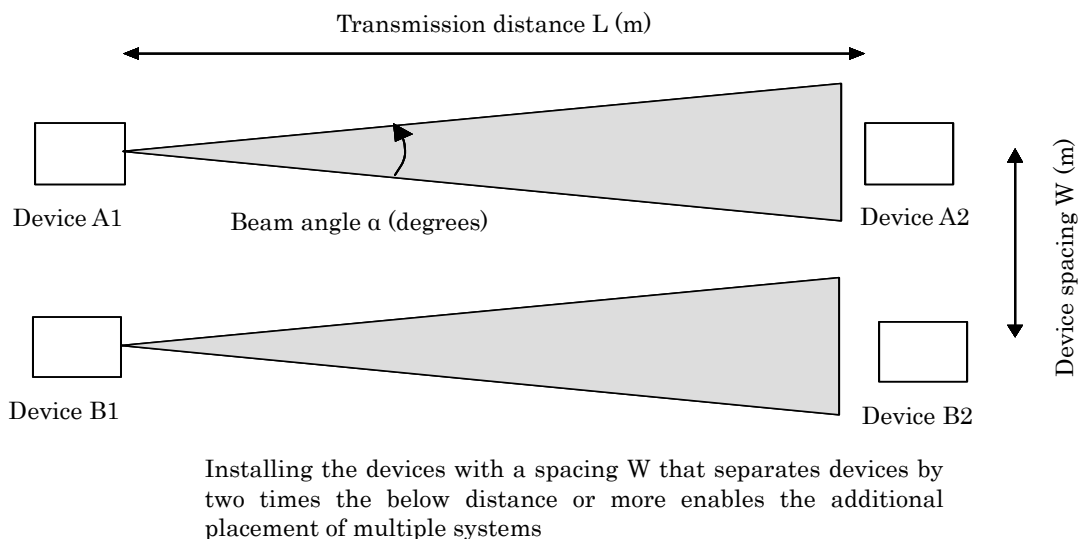

$2L \tan(\alpha/2)$: Distance where beams overlap each other

Fig. 11-1 Typical installation of outdoor beam transmission device

References

- (1) ISO/IEC 8802-3:2000 "Carrier sense multiple access with collision detection (CSMA/CD) access method and physical layer specifications"
- (2) IEC 60825-1:2000 "Equipment classification, requirements and users guide"
- (3) ISO/IEC 8802-2:1998 "Logical link control"

Version 3.0 Revision History Table

Chapter	Section number, etc.	Details of revision in Version 3.0
Title		<p>INFRARED WIRELESS LAN SYSTEM → OPTICAL WIRELESS LAN SYSTEM</p>
All pages		<p>b/s → bps infrared → optical wireless/light ISO/IEC 8802-3 → ISO/IEC 8820-3:2000</p>
Chapter 1	<p>1.1 Line 2</p> <p>1.2 Line 2</p> <p>Line 8</p>	<p>The ARIB Standard provides for 10Mb/s Infrared Wireless LAN System which adopts infrared medium as physical layers to secure entire compatibility with the ISO/IEC 8802-3 "CSMA/CD Local Area Network (LAN) Specification." → <u>This standard provides for 10Mbps optical wireless LAN, 100Mbps optical wireless LAN, and 1000Mbps optical wireless LAN systems that adopt optical wireless media as physical layers to secure compatibility with the ISO/IEC 8802-3:2000 "CSMA/CD Local Area Network (LAN) Specification".</u></p> <p>The ARIB Standard provides for the 10Mb/s Infrared Wireless LAN which is compatible with the ISO/IEC 8802-3 are roughly classified into the two categories, a common section which does not depend on transmission medium and the other section which is medium-dependent. → <u>This standard provides for the 10Mbps optical wireless LAN, 100Mbps optical wireless LAN, and 1000Mbps optical wireless LAN systems, which are compatible with ISO/IEC 8802-3:2000.</u> <u>This standard also follows the format of ISO/IEC 8802-3:2000.</u> <u>ISO/IEC 8802-3:2000 is roughly classified into the two categories, a common section which does not depend on transmission medium and the other section, which is medium-dependent.</u></p> <p>For the section which does not depend on transmission media, the ARIB Standard cites the provisions of the ISO/IEC 8802-3 as they are, while, for the medium-dependent section, it cites the provisions of the type 10BASE-T whenever needed and additionally it cites those of the 10Mb/s baseband infrared types mutatis mutandis.</p>

	<p>Line12</p> <p>Line 17</p> <p>Line 21</p>	<p>→ For the section which does not depend on transmission media, <u>this standard cites the provisions of the ISO/IEC 8802-3:2000 as they are, while, for the medium-dependent section, it cites the provisions of the type 10BASE-T, the provisions of the type 100BASE-T, the provisions of the type 1000BASE-T, and the provisions of the type X as required, and additionally cites those of the 10 Mbps, 100 Mbps, and 1000 Mbps baseband optical wireless types, revised as necessary.</u></p> <p>In adding and modifying them, the basic requirements of mutual connectability of products have been paid to secure a degree of freedom in implementation of products and the possibilities for the element technology to be further improved in the future, thereby the balance being kept well between them.</p> <p>→ <u>In making additions and modifications, attention has been paid to meet the basic requirements for mutual connectability of products while at the same time seeking to ensure the freedom for implementation in products and retaining the latitude for future improvements in the element technology.</u></p> <p>More concretely, the requirements for the MAC and PLS sublayers, AUI, and repeater units have been cited from Chapters 2 through 7, and 9 of the ISO/IEC 8802-3.</p> <p>→ More concretely, the requirements for the MAC and PLS sublayers, AUI, and repeater units <u>with regard to a 10 Mbps optical wireless LAN have been cited from Chapters 2 through 7, and 9 of the ISO/IEC 8802-3:2000.</u></p> <p><u>The requirements for the MAC sublayer and media access protocol for 100 Mbps and 1000 Mbps optical wireless LAN have been cited from Chapters 2 through 4 of the ISO/IEC 8802-3:2000. Chapter 6 of this standard cites the provisions of Chapters 21, 22, and 24 through 31 of the ISO/IEC 8802-3:2000 as required, and the provisions related exclusively to the optical wireless units are added to them. Chapter 10 of this standard cites the provisions of Chapters 34 through 37 and Chapters 40 through 43 of the ISO/IEC 8802-3:2000 as required, and</u></p>
--	---------------------------------------------	----------------------------------------------------------------------------------------------------------------------------------------------------------------------------------------------------------------------------------------------------------------------------------------------------------------------------------------------------------------------------------------------------------------------------------------------------------------------------------------------------------------------------------------------------------------------------------------------------------------------------------------------------------------------------------------------------------------------------------------------------------------------------------------------------------------------------------------------------------------------------------------------------------------------------------------------------------------------------------------------------------------------------------------------------------------------------------------------------------------------------------------------------------------------------------------------------------------------------------------------------------------------------------------------------------------------------------------------------------------------------------------------------------------------------------------------------------------------------------------------------------------------------------------------------------------------------------------------------------------------------------------------------------------------------------------------------------------------------------------------------------------------------------------------------------------------------------------------------------------------------------------------------------------------------------------------------------------------------------------------------------------------------------------------------------------------------------------------------------------------------------------------------------------

		<u>the provisions related exclusively to the optical wireless units are added to them.</u>
Chapter 2	title	MAC and PLS Sublayers, AUI, and Repeater Units → MAC and PLS Sublayers, AUI, and Repeater Units(10Mbps)
Chapter 3	title	Infrared Medium Attachment Unit (IR MAU) and Baseband Medium (10Mb/s baseband infrared type) → <u>Optical Wireless Media Access Unit (MAU) and Baseband Medium (10Mbps Baseband Optical Wireless Type)</u>
	3.1.1	Line 2 Chapter 3 defines the functional, electrical, and optical characteristics of the 10 Mb/s baseband IR MAU and a specific medium for use with the MAU. → Chapter 3 defines the functional, electrical, and optical characteristics of the 10Mbps baseband optical wireless MAU and the specific <u>baseband</u> medium for use with the MAU.
		Line 6 Fig.1 → <u>Fig. 3-1</u>
		Line 11 transmission areas cover 1m to tens of meters. → transmission areas cover from <u>about one meter</u> to <u>several</u> tens of meters.
		Line 12 Installation and reconfiguration simplicity is allowed by using the types of an infrared MAU and baseband medium. → <u>Simplicity in installation and reconfiguration is allowed by use of the optical wireless type MAU and baseband medium.</u>
		Line 13 Since, moreover, infrared beams do not transmit walls and are attenuated after passing external chambers, the infrared system has such characteristics as substantial reduction of interference of communications and possibilities of wiretapping from exterior. → <u>Moreover, since light beams are blocked at walls and are attenuated after passing through exterior windows, the characteristics of the optical system include the ability to substantially reduce the possibility of interference in communications and external wiretapping.</u>
		Line 17 On the other hand, the safety regulations on infrared irradiation are under review by the Technical Committee TC-76 of the IEC.

	<p>Line 18</p> <p>Fig. 3-1</p> <p>3.1.1.1 (1)</p> <p>3.1.1.1 (5)</p> <p>3.1.1.1 (6)</p>	<p>→ On the other hand, the safety regulations on <u>photoradiation</u> are under review by the Technical Committee TC-76 of the IEC.</p> <p>A standard on LD have been established as IEC 825-1 while that on IRED is now under discussion. Hence, this standard cites the regulations given in the IEC 825-1 regarding the LD, and the contents of the discussion in the TC-76 are separately reviewed regarding the IRED.</p> <p>→ <u>A standard has been established as IEC 60825-1 Edition1.2. This standard will comply with this standard in methods of measurement and classification.</u></p> <p>Fig.1 → <u>Fig. 3-1</u></p> <p>The Standard → This standard</p> <p>APPLICATION → APPLICATION <u>Layer</u></p> <p>PRESENTATION → PRESENTATION <u>Layer</u></p> <p>SESSON → SESSON <u>Layer</u></p> <p>TRANSPORT → TRANSPORT <u>Layer</u></p> <p>NETWORK → NETWORK <u>Layer</u></p> <p>DATA LINK → DATA LINK <u>Layer</u></p> <p>PHYSICAL → PHYSICAL <u>Layer</u></p> <p>Enables coupling the Physical signaling (PLS) sublayer by way of the Attachment Unit—SInterface (AUI) to the baseband infrared link defined in Chapter3.</p> <p>→ <u>Enables coupling of the physical layer signaling (PLS) sublayer by way of the Attachment Unit Interface (AUI) to the optical wireless link defined in Chapter 3.</u></p> <p>Supports a point-to-point interconnection between MAUs and a star wiring topology.</p> <p>→ <u>Supports a point-to-point or a star interconnection between MAUs.</u></p> <p>Allows incorporation of the MAU within the physical bounds of a DTE or repeater unit.</p> <p>→ <u>MAU can be contained within DTE or repeater unit.</u></p>
--	-----------------------------------------------------------------------------------------	---------------------------------------------------------------------------------------------------------------------------------------------------------------------------------------------------------------------------------------------------------------------------------------------------------------------------------------------------------------------------------------------------------------------------------------------------------------------------------------------------------------------------------------------------------------------------------------------------------------------------------------------------------------------------------------------------------------------------------------------------------------------------------------------------------------------------------------------------------------------------------------------------------------------------------------------------------------------------------------------------------------------------------------------------------------------------------------------------------------------------------------------------------------------------------------------------------------------------------------------------------------------------------------------------------------------------------------------------------------------------------------------------------------------------------------------------------------------------------------------------------------------------------------------------------------------------------------------------------------------------------------------------------------------------------------------------------------------------------------------

	<p>3.1.1.2 Line 3</p> <p>3.1.1.3 Line 1 Line 3</p> <p>3.1.2 (2)</p> <p>3.1.2 (7)</p> <p>3.1.2 (8)</p> <p>3.1.2 (9)</p> <p>3.1.3.1 (3)</p> <p>3.2 (1)-(7)</p> <p>3.2.1 Line 4</p>	<p>two or more segments. → <u>multiple</u> segments.</p> <p>Repeaters are an integral part of all 10 Mb/s baseband infrared networks with more than two DTEs.</p> <p>→ <u>Repeaters are an essential part of 10Mbps baseband optical wireless networks with multiple DTEs.</u></p> <p>Infrared medium → <u>Optical wireless media</u></p> <p>Infrared light-emitting elements used are IRED or LD and photo-detecting elements are PD.</p> <p>→ <u>The light-emitting elements used are LED or LD and photo-receiving elements are PD.</u></p> <p>A condition that results from concurrent transmission from multiple signal sources.</p> <p>→ <u>An undesirable condition that results from concurrent transmission from multiple signal sources.</u></p> <p>Infrared link</p> <p>infrared link segment and two MAUs connected to it.</p> <p>→ <u>Optical wireless link</u></p> <p><u>Optical wireless link segment and two MAUs connected to it.</u></p> <p>infrared link segment → <u>Optical wireless link segment</u></p> <p>Infrared emitting diode (IRED) → <u>Light emitting diode (LED)</u></p> <p>service → <u>maintenance</u></p> <p>Provides the ability to → <u>The ability to</u></p> <p>A capability may be provided in the MAU to activate or inhibit the SQE Test function.</p> <p>An MAU is not required to determine that it is connected to either a DTE or a repeater and automatically activate or inhibit the SQE Test function.</p> <p>→ <u>The SQE Test function activation and inhibition feature is provided in the MAU. The MAU is not required to determine whether it is connected to a DTE or a repeater and to automatically activate or</u></p>
--	--------------------------------------------------------------------------------------------------------------------------------------------------------------------------------------	---------------------------------------------------------------------------------------------------------------------------------------------------------------------------------------------------------------------------------------------------------------------------------------------------------------------------------------------------------------------------------------------------------------------------------------------------------------------------------------------------------------------------------------------------------------------------------------------------------------------------------------------------------------------------------------------------------------------------------------------------------------------------------------------------------------------------------------------------------------------------------------------------------------------------------------------------------------------------------------------------------------------------------------------------------------------------------------------------------------------------------------------------------------------------------------------------------------------------------------------------------------------------------------------------------------------------------------------------------------------------------------------------------------------------------------------------------------------------------------------------------------------------------------------------------------------------------------------------------------------------------------------------------------------------------------------------------------------------------------------------------------------------------------------------------------------------------

	3.3.1.3	<p><u>inhibit the SQE Test function.</u></p> <p>Class 1 as provided for in IEC 825-1 is recommended for LD, but this provision does not preclude the use of other classes. Output power for IRED is separately reviewed</p> <p>→ <u>For indoor applications, Class 1 as provided for in IEC 60825-1 Edition 1.2 is recommended, and for outdoor applications, Class 1 or 1M is recommended.</u></p>
Chapter 4	<p>Title</p> <p>(1) Line 3</p> <p>Line 10</p> <p>(2) Line 15</p> <p>Line 19</p> <p>Line 26</p> <p>Line 30</p> <p>(3) Line 4</p> <p>Line 5</p> <p>Line 11</p> <p>Line 13</p>	<p><u>(10Mbps)</u></p> <p>It aims to be applied mainly to a through space in an office.</p> <p>→ <u>It is targeted mainly at office through space applications.</u></p> <p>Fig.2 → Fig.4-1</p> <p>Fig.3 → Fig. 4-2</p> <p>entered → inputted</p> <p>The above-mentioned infrared MAU compares the data transmitted from the TD circuit and those received at the RD circuit, and as long as they agree with each other, the repeater does not transmit the data received by the RD circuit to the DI circuit.</p> <p>When they come to disagree, it starts transmitting them.</p> <p>→ <u>The relevant optical wireless MAU compares the data transmitted from the TD circuit and those received at the RD circuit, then it is not transmitting the data received at RD circuit to DI circuit while the data is matched, transmitting to DI circuit when it is unmatched.</u></p> <p>This means that the repeater always monitors whether or not a collision exists, namely, whether or not the data it transmits to the infrared link segment are not broken by a collision. → Herewith the repeater can always monitor whether a collision exists or not ,which means, whether or not the data it transmits to the optical wireless link segment are not corrupted by a collision.</p> <p>includes → include</p> <p>packed → integrated</p> <p>expansion of linkages → connectivity</p> <p>Fig.4 → Fig. 4-3</p>

	(4) Line 2	Table 1 → <u>Table 4-1</u>
	Fig. 4-1	Fig.2 → <u>Fig. 4-1</u>
	Fig. 4-2	Fig.3 → <u>Fig. 4-2</u>
	Fig. 4-3	Fig. 4 → <u>Fig. 4-3</u>
	Table 4-1	Table 1 → <u>Table 4-1</u>
	Column 2 row 1	One-to-one Long-distance system
	Column 3 row 1	One-to-n Medium-distance system
	Column 4 row 1	One-to-one Short-distance system
	Column 1 row 6	Data transmitting speed → Data transfer rate
	Column2 row 13	Power source
	Column2 row 14	Power source
	Column4 row 13	Power source
	Column4 row 14	Power source
Chapters 5-11		Added chapters.
References	(1)	ISO/IEC 8802-3: 1993 "Carrier sense multiple access with collision detection (CSMA/CD) access method and physical layer specifications → <u>ISO/IEC 8802-3:2000 "Carrier sense multiple access with collision detection (CSMA/CD) access method and physical layer specifications"</u>
	(2)	IEC 825-1: 1993 "Equipment classification, requirements, and users' guide" → <u>IEC 60825-1:2000 "Equipment classification, requirements and users guide"</u>
	(3)	ISO/IEC 8802-2: 1994 "Logical link control" → <u>ISO/IEC 8802-2:1998 "Logical link control"</u>

Notes:

- 1) This table lists the latest (after-revision) page and section numbers, etc.
- 2) Parts which have been crossed out were deleted from the standard of the previous edition.
- 3) Parts which are underlined were added as part of the latest revision.
- 4) Unless an explanatory note indicates otherwise, the numbers given for the lines are counted down from the title in the section or paragraph concerned.

OPTICAL WIRELESS LAN SYSTEM
ARIB STANDARD
ARIB STD-T50 VERSION 3.0

Version 1.0	February	1997
Version 2.0	May	2002
Version 3.0	December	2006

Published by
Association of Radio Industries and Business

Nittochi Bldg. 11F
1-4-1 Kasumigaseki, Chiyoda-ku, Tokyo 100-0013 Japan

TEL 81-3-5510-8590
FAX 81-3-3592-1103

Printed in Japan
All right reserved

Distribution Price ¥1,323
(including Japanese consumption tax)